

**JVC**<sup>®</sup>  
**PROFESSIONAL**

D-ILA™ PROJECTOR  
**DLA-M5000SC/M5000L**

Beyond The Next Level:  
Welcome To The Future Of Image Projection

**SXGA**  
**5000**  
**ANSI LUMENS**





# TRUE SXGA 5000 ANSILUMENS Proven D-ILA™ Performance, An Incredible Super C

For years, multimedia projection systems have existed in the shadow of the superior picture quality of traditional film projectors. No more. The future of projection is here. Now JVC introduces a pair of super-charged digital graphics/video projectors that bring you performance that's truly ahead of its time. You'll get bright, super-sharp, high-resolution S-XGA images on screens up to 50 ft (15 m) across (measured diagonally). And thanks to JVC's breakthrough D-ILA™ (Direct Drive Image Light Amplifier) and unprecedented ultra-high brightness of 5000 ANSI lumens, those images easily rival the intensity and brilliance of a film projector. In fact, with the DLA-M5000SC's industry-leading contrast ratio of 1000:1, you'll get clear, dead-sharp images even in a large, brightly lit room. Just as remarkable is the fact that all of that power and brilliance is packed into a design that installs easily just about anywhere and can be stacked to deliver bigger, brighter images to suit any size venue.



## D-ILA™ — A Breakthrough In Projection Technology



The core of D-ILA™ (Direct Drive Image Light Amplifier) projector device is a high-density reflective type LCD able to project high-resolution images. With a homeotropic structure in which the LCD elements are aligned vertically, the D-ILA™ device produces extra-bright, high-contrast images ideal for big-screen projection applications.

The key to more affordable home and general presentation projectors, the new 0.7" S-XGA+ (1,400 x 1,050) device is able to take advantage of higher yield, allowing it to lower cost while offering a higher resolution.

Also coming soon is the industry leading Q-XGA (2,048 x 1,536) device. Offering full HDTV (1080i) compatibility without compression, as well as D-ILA™'s hallmark crystal clear picture quality, Q-XGA is destined to become the premier display technology for digital cinema and other high-end applications.

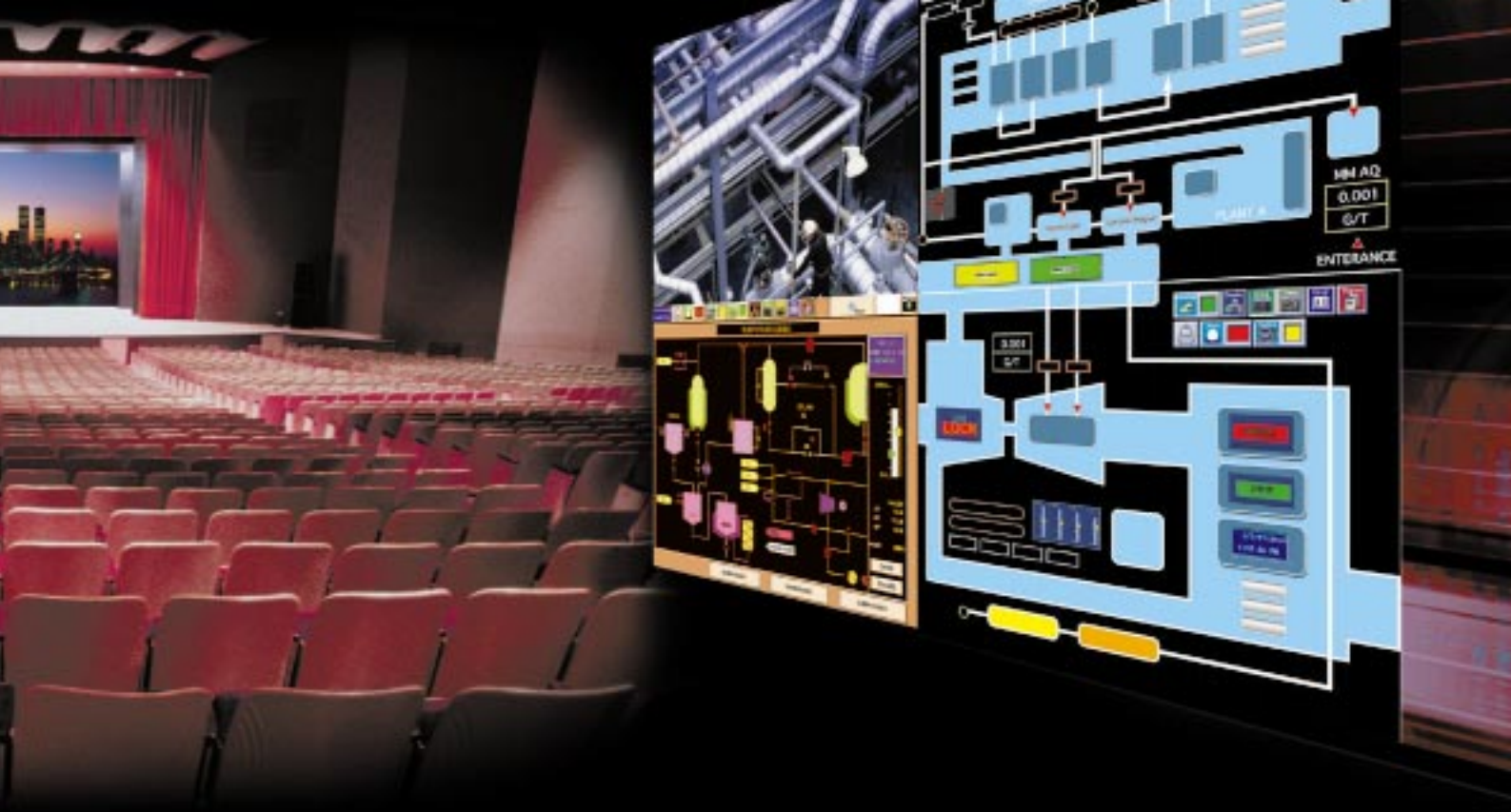

# 1000:1 Super Contrast Ratio contrast, And 5000 ANSI Lumens Of Sheer Brilliance

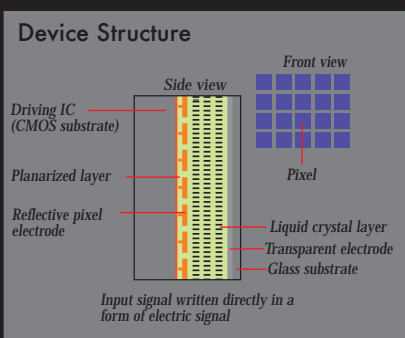
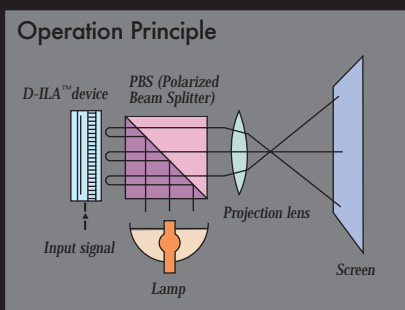

## D-ILA™ technology – the secrets of superior quality

### • Higher brightness and resolution

LCD panels are composed of a dense array of pixels which are illuminated individually to produce patterns and images. In conventional “transmissive” LCD panels, the driving transistor which activates the pixels is mounted on the same surface as the pixels, so limiting the inherent degree of brightness and resolution. With JVC’s D-ILA™ device, on the other hand, the driving IC substrate is located behind the liquid crystal layer, so making it possible to achieve much higher levels of brightness and resolution than conventional devices.

### Large-screen projection with compact design

The D-ILA™’s high light efficiency maximizes the light output power for large screen projection without requiring a large, bulky projection unit. In combination with an advanced system that makes it possible to write the input signal directly on the D-ILA™ device in the form of an electric signal, this super-efficient technology has enabled us to simplify the projector’s design and incorporate small 0.9” devices. The result is outstanding projection power in a remarkably compact, lightweight unit.

### Sharp, noiseless image

By minimizing the space between pixels, the D-ILA™’s high-density structure and extra-high aperture ratio of 93% effectively eliminate stripe noise and producing crisp, clear images from edge to edge with well-defined details and vivid, true-to-life color.

### Higher contrast

Another advantage of the D-ILA™ device is the vertical alignment (“homeotropic” structure) of the liquid crystal layer. This ensures that projected images have extra high contrast and makes it possible to accurately reproduce even very subtle gradation differences between the lighter and darker parts of the projected image.

# Powerful next-generation projection performance and multi-application versatility

**5000 ANSI Lumens**

**1000:1 Super Contrast Ratio**

## High-Brightness 5000 ANSI Lumens

The D-ILA™'s high light efficiency is supported by a powerful 1.6kW Xenon lamp enables the DLA-M5000SC/L to generate an amazing 5000 ANSI lumens of brightness. This powerful light output makes it possible to project clear, bright, highly visible images even in a bright room. Exclusive light condensing technology is also incorporated which increases the ratio of peripheral light to 80%, ensuring uniform brightness in all areas of the screen.

• Brightness is ensured in all areas of screen.



• Poor brightness in peripheral



## 1000:1 Super Contrast Ratio (DLA-M5000SC)

Contrast is what brings out the details and when it comes to contrast, nothing compares to JVC's DLA-M5000SC. Boasting a super high contrast ratio of 1000:1, this one-of-a-kind projector brings to life even the tiny details that would normally be lost in the darker portions of the picture. The result is unprecedented depth that produces images so realistic they literally jump off the screen.

## Xenon Lamp for Natural Color Reproduction

The powerful 1.6kW Xenon lamp incorporated in the DLA-M5000SC/L assures true color reproduction and natural images — with quality comparable to those seen in movie theaters. Unlike the metal halide lamps used in conventional projectors, which tend to produce colors with a bluish tinge, the Xenon lamp accurately reproduces the original image colors, assuring natural, unmediated color reproduction.

## 10-Bit Digital Gamma Correction

For more accurate gray scale reproduction, the DLA-M5000SC/L features newly developed 10-Bit Digital Gamma Correction circuitry able to precisely reproduce even minor tone differences. In combination with the natural emission spectrum of the Xenon lamp, this further enhances the natural characteristics of the projected color.



• Poor gradation reproduction



• Accurate gradation reproduction

## True S-XGA Resolution

When projected onto a large-size screen, the DLA-M5000SC/L's high-density LCD panels provide true S-XGA resolution without scaling or loss of quality. With a total of 4,193,280 image dots, even the small characters and icons typical of computer displays can be reproduced clearly. This makes the DLA-M5000SC/L the perfect choice for projection of high-resolution 3D graphics or detailed CAD images.

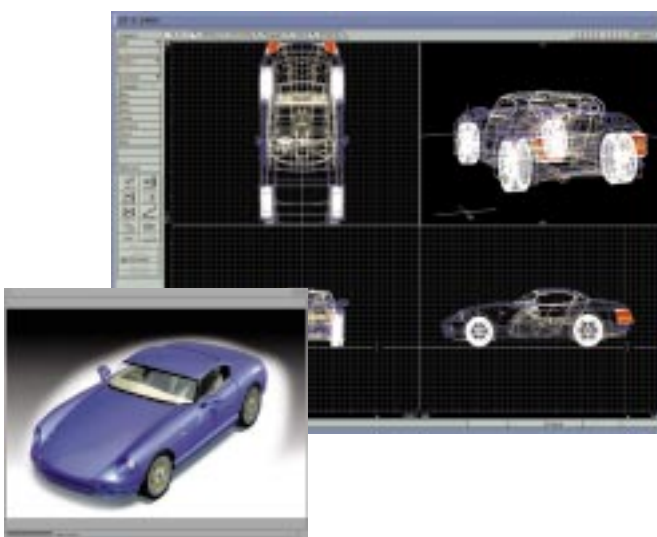

**SXGA**

## Resizing Function with Adaptive DPC Circuitry

You may not always want or need to project S-XGA images. To ensure that the DLA-M5000SC/L is versatile enough to meet your projection requirements, we have also included our innovative Adaptive DPC (Digital Pixel Conversion) circuitry. This enables the D-ILA™ projector to project XGA (1024 x 768 pixels), S-VGA (800 x 600 pixel), and VGA (640 x 480 pixels), as well as true S-XGA (1365 x 1024 pixels). Optimum pixel conversion is performed by the Adaptive DPC according to the characteristics of the source signal to ensure a clear, undistorted image.

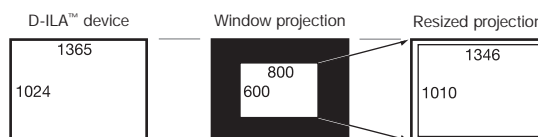

Ex.: S-VGA image projection

When the number of pixels used in the image data being projected differs from the built-in device, you can use either the "Window projection" or "Resizing projection" method.



## 600-inch

### 600" Large-Screen Projection

Thanks to its super-high brightness and advanced D-ILA™ device, the DLA-M5000SC/L can project bright, high-contrast images onto full-size theater-scale screens. At the 4:3 aspect ratio, possible screen sizes (diagonal) range from 60" – 300" (recommended), all the way up to 600" (max.).\* *\*When using zoom lens*

Relationship between screen width and throw distance

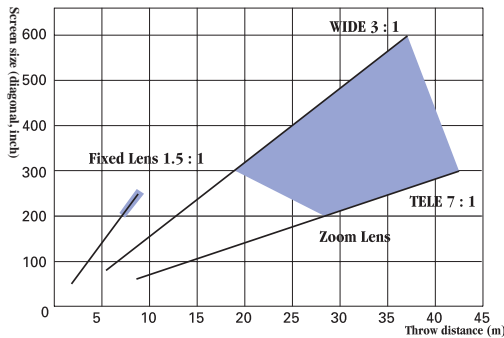

In the shaded areas in the graph, the projected image may be partially distorted or missing depending on the distance between the projector and the screen. To project an image with no image distortion or missing image sections, we recommend you use the projector in the areas defined with a solid lines in the graph.

With GL-M4010 1:1 Fixed lens Recommended screen size: 85"– 150" (4:3 aspect ratio)

| Screen size (inch)  | 80   | 100  | 100  | 150  | 200   |
|---------------------|------|------|------|------|-------|
| Throw distance (m)  | 1.54 | 1.95 | 2.37 | 2.99 | 1.03  |
| Throw distance (ft) | 5.05 | 6.40 | 7.77 | 9.81 | 13.22 |

With GL-M4015S 1.5:1 Fixed lens Recommended screen size: 70"– 200" (4:3 aspect ratio)

| Screen size (inch)  | 65    | 70    | 80    | 90    | 100   | 110   | 120   | 130   | 140   | 150   |
|---------------------|-------|-------|-------|-------|-------|-------|-------|-------|-------|-------|
| Throw distance (m)  | 1.97  | 2.13  | 2.44  | 2.76  | 3.08  | 3.39  | 3.71  | 4.03  | 4.34  | 4.66  |
| Throw distance (ft) | 6.46  | 6.99  | 8.01  | 9.06  | 10.10 | 11.12 | 12.17 | 13.22 | 14.24 | 15.29 |
| Screen size (inch)  | 160   | 170   | 180   | 190   | 200   | 210   | 220   | 230   | 240   | 250   |
| Throw distance (m)  | 4.98  | 5.29  | 5.61  | 5.93  | 6.24  | 6.56  | 6.88  | 7.20  | 7.51  | 7.83  |
| Throw distance (ft) | 16.34 | 17.36 | 18.41 | 19.46 | 20.47 | 21.52 | 22.57 | 23.62 | 24.64 | 25.69 |

With GL-M4023SZ 2.3x (3:1–7:1) Zoom lens Recommended screen size: 60"– 300" (4:3 aspect ratio)

| Screen size (inch)   | 60          | 80          | 100         | 120          | 140          | 160          | 180         |
|----------------------|-------------|-------------|-------------|--------------|--------------|--------------|-------------|
| Wide (shortest) (m)  | --8.65      | 5.06–11.50  | 6.30–14.34  | 7.53–17.19   | 8.77–20.03   | 10.00–22.87  | 11.24–25.72 |
| —Tele (longest) (ft) | --28.38     | 16.60–37.73 | 20.67–47.05 | 24.70–56.40  | 28.77–65.72  | 32.81–75.03  | 36.88–84.38 |
| Screen size (inch)   | 200         | 220         | 240         | 260          | 280          | 300          | 350         |
| Wide (shortest) (m)  | 12.47–25.72 | 12.47–25.72 | 12.47–28.56 | 16.18–37.10  | 17.42–39.42  | 18.65–42.79  | 21.74--     |
| —Tele (longest) (ft) | 40.91–84.38 | 40.91–84.38 | 40.91–93.70 | 53.08–121.72 | 57.15–129.33 | 61.19–140.39 | 71.33--     |
| Screen size (inch)   | 400         | 450         | 500         | 550          | 600          |              |             |
| Wide (shortest) (m)  | 24.83--     | 27.92--     | 31.01--     | 34.10--      | 37.19--      |              |             |
| —Tele (longest) (ft) | 81.46--     | 91.60--     | 101.74--    | 111.88--     | 122.01--     |              |             |

### Stackable Design For Enhanced Projection Power

For maximum versatility, the DLA-M5000SC/L has been designed for easy integration into a stacked configuration. By mounting one projector on top of another projector, you can project a combined image onto a single screen, allowing you to achieve even higher levels of brightness than is possible with a single projector. This makes the DLA-M5000SC/L suitable for use even in very large rooms with bright ambient light such as event halls.



The projector's base can easily be attached to the top panel of another unit.

### Lens Shift Function

The DLA-M5000SC/L features a convenient Lens Shift function that is ideal for use in stacked configurations or off-center installations. This allows you to easily align the lenses of two projectors by moving the lens up or down and left or right. Up/down shift is ±50% (motorized) and left/right shift is ±32% (manual). As a result, you can install the projector virtually anywhere in a room and still produce a clear, undistorted picture on the screen.

Note: The shift range is narrowed when the up/down and left/right shift are engaged simultaneously. Shift percentage estimates are based on the screen height which is regarded as 100%.

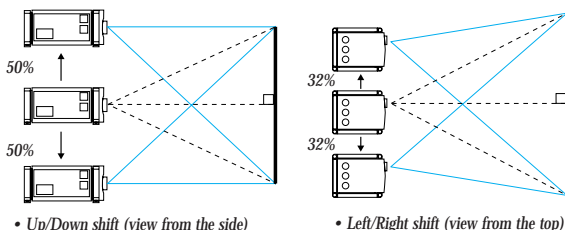

### Versatile Multi-Sync Signal Input Capability

To assure compatibility with the widest range of multi-media applications and signal formats, the DLA-M5000SC/L's sync frequency covers 15 to 82kHz (horizontal) and 50 to 78Hz (vertical). Two PC inputs are provided so you can simultaneously input signals from two different computers and switch between them as required.



### Digital TV Ready\*

The DLA-M5000SC/L is compliant with various digital TV formats including 480i, 480p, 720p and 1080i.

\*External DTV decoder required to receive digital television broadcasts

### Easy Handling & Setup

Thanks to its simple, uncomplicated design and small-scale 0.9" projection device, the DLA-M5000SC/L is surprisingly compact and lightweight for a machine of this class. At 157lbs (71kg), these projectors also come with a host of user-friendly functions for "hassle-free" operation, including a quick alignment function for automatic adjustment of tracking, phase and position, remote-operated power zoom and power focus for adjustment of screen size, and a handy multi-function remote control.

### Other Features

- Up-down/left-right inversion
- Selectable color temperature (High/Mid/Low)
- Selectable background color (when no signal is input)
- Lamp life warning indicator
- Warning indicator
- On-Screen Menu



# Systems flexibility makes this unit of professional applications

## Conference/Lecture

Clear, easy-to-see image makes sure your audience gets your message.

When you want to provide information to a large audience (for example, in a lecture hall at a university), you'll find the DLA-M5000SC/L's big, bright image makes it ideal for the task. The sharp, detailed image is bright and clear in all areas of the big screen and is easy to view even from a distance. Since there's no need to turn the lights down, images can be projected as needed without interrupting the flow or structure of the lecture.



### System Configurations

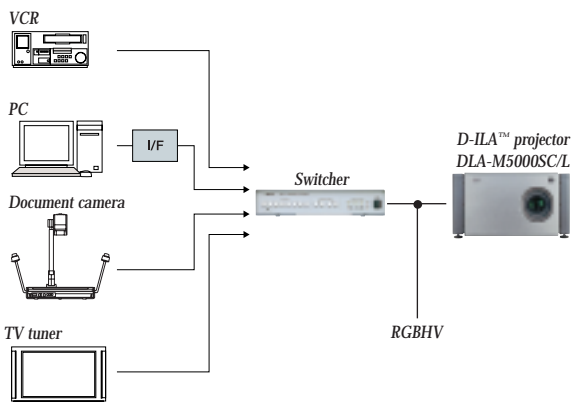

## Events/Shows

Attract a crowd with high-quality, big-screen demonstrations.

Draw the crowds to your booth at large-scale events and exhibitions with the dazzling, big-screen images of the DLA-M5000SC/L. Its stackable design makes it possible for you to use more than one unit to display images on larger screens even in really big, bright spaces, while its flexible design and superior operability ensure quick, easy setup and trouble-free operation.



### System Configurations

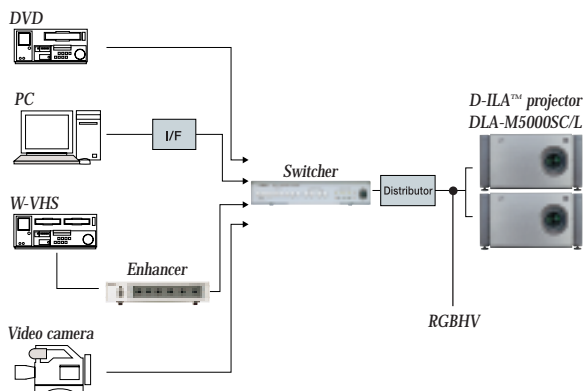

# ideal for a wide range

## Presentation/Development/Designing

High-impact image reproduction makes your presentation more persuasive.

Since its image has none of the fuzziness or washed-out look common to conventional video projectors, the DLA-M5000SC/L high-resolution projector is ideal for displaying small characters, detailed images, and high-resolution graphics. Images from PCs, or workstations retain all the quality of the original, ensuring that nothing is lost in the transition to the big screen and making your presentation even more impressive.

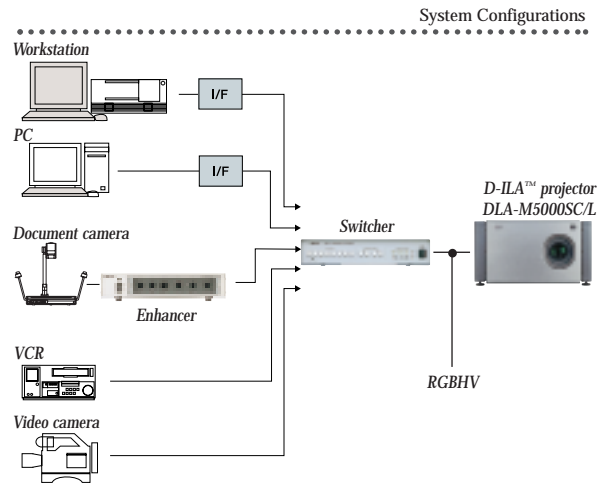
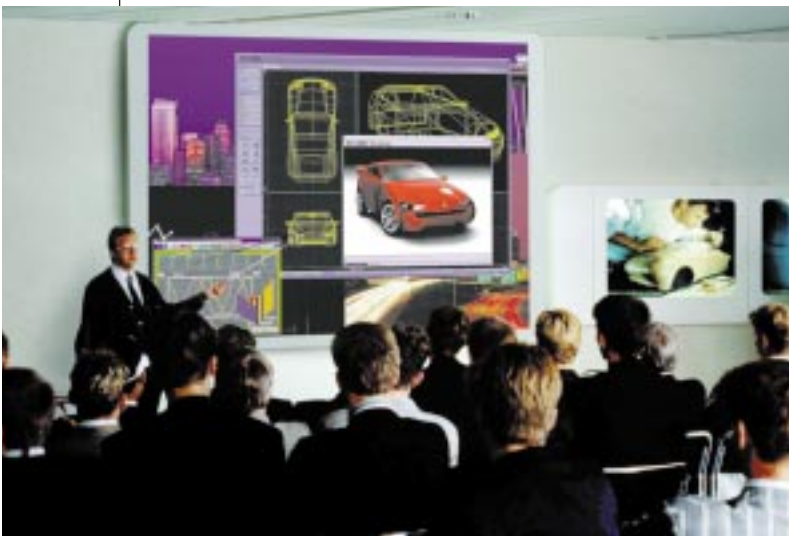

## Monitoring/Security

High-precision display monitors the situation in detail.

Ideal for monitoring and security management in large facilities or traffic control centers where detailed monitoring is critical, the DLA-M5000SC/Ls high-precision multi-source projection capability and systems flexibility makes it an excellent choice for a centralized monitoring system.

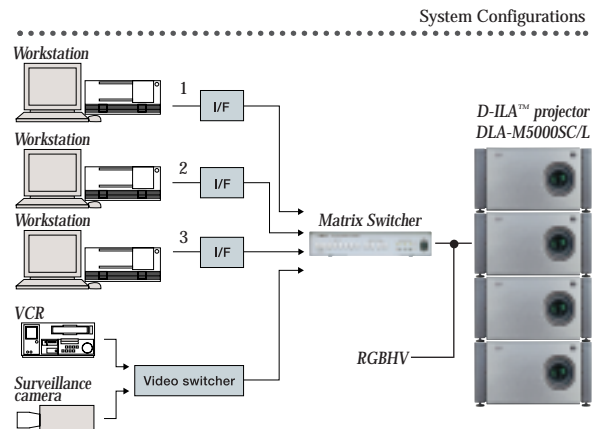

## Specifications

|                        |                                                                                                                                                      |
|------------------------|------------------------------------------------------------------------------------------------------------------------------------------------------|
| Image Device           | 3 D-ILA devices (0.9 inches diagonal)                                                                                                                |
| Projection Lens        | Optional (see below)                                                                                                                                 |
| Lamp                   | 1.6KW, Xenon lamp                                                                                                                                    |
| Brightness             | 5,000 ANSI lumens                                                                                                                                    |
| Resolution             | 1,365 x 1,024 pixels, full coverage of S-XGA(1,280 x 1,024)<br>Graphics (S-XGA, XGA, S-VGA, VGA)                                                     |
| Contrast Ratio         | DLA-M5000SC: 1000:1<br>DLA-M5000L: More than 350:1                                                                                                   |
| Uniformity             | More than 80%                                                                                                                                        |
| Screen Size            | (3:1 – 7:1 zoom): 60" – 600" (1,219 mm – 12,192 mm)<br>(1.5:1): 65" – 250" (1,321 mm – 5,080 mm)<br>(1:1): 80" – 200" (1,626 mm – 4,064 mm)          |
| Throw Distance         | (3:1 – 7:1 zoom): 16.6 – 140 ft (5.1 m – 42.7m)<br>(1.5:1): 6.5 – 25.7 ft (2.0 m – 7.8 m)<br>(1:1): 5.1 – 13.2 ft (1.6 m – 4.0 m)                    |
| Sync Frequency         | Horizontal: 15kHz – 82kHz<br>Vertical: 50Hz – 78Hz                                                                                                   |
| Input                  | PC (Mini D-sub 15-pin) x 1    Composite x 1<br>RGBHV (BNC) x 1            Y/C-Separated x 1<br>Y, P <sub>B</sub> /B-Y, P <sub>R</sub> /R-Y (BNC) x 1 |
| Output                 | PC (Mini D-sub 15-pin) x 1                                                                                                                           |
| Power Requirement      | AC 200V – 240V, 50/60 Hz                                                                                                                             |
| Power Consumption      | 2,200 W                                                                                                                                              |
| Dimensions (W x H x D) | 29.4" x 14.5" x 31.2" (747 x 368 x 793 mm) (without protrusion)                                                                                      |
| Weight                 | 157 lbs (71 kg) (without lens)                                                                                                                       |

## Optional Accessories



GL-M4023SZ  
2.3x (3:1-7:1) Zoom Lens



GL-M4015S  
1.5:1 Fixed Lens



GL-M4010  
1:1 Fixed Lens

D-ILA is a registered trademark of Victor Company of Japan, Limited

E. & O.E. Design and specifications are subject to change without notice.

All brand names and product names are trademarks, registered trademarks, or trade names of their respective holders.

All photographs and screenshots in this catalog are simulated.

Copyright © 2001, Victor Company of Japan, Limited (JVC). All rights reserved.

# JVC®

DISTRIBUTED BY:

JVC PROFESSIONAL PRODUCTS COMPANY  
DIVISION OF JVC AMERICAS CORP.  
1700 Valley Road, Wayne N.J. 07470  
TEL: 973-315-5000, 1-800-526-5308 FAX: 973-315-5030  
<http://www.jvc.com/pro>

JVC CANADA INC.  
21 Finchdene Square, Scarborough Ontario M1X 1A7  
TEL: 416-293-1311 FAX: 416-293-8208  
<http://www.jvcpro.com>

## Dimensions

Unit: inch (mm)

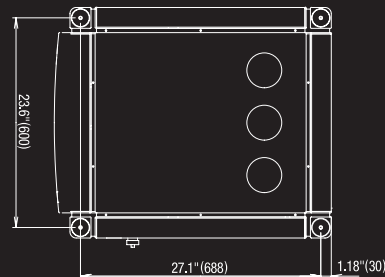
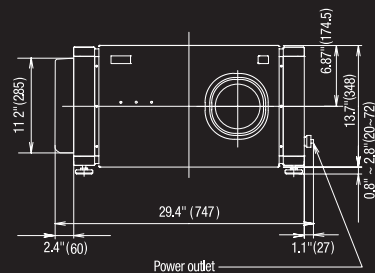
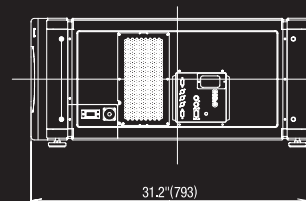

Printed in Japan  
DLAC-0104 (U)