

企画承認	承認	照査	作成

# **D-ILA<sup>TM</sup> PROJECTOR**

**DLA-G20/DLA-M4000**

RS-232C CONTROL SPECIFICATIONS

Victor Company of Japan, Limited

\* D-ILA is a trademark of Victor Company of Japan, Limited.

# CONTENTS

1. Outline .....	2
2. Communication Format.....	2
3. Data Format .....	2
4. Header .....	4
5. ID.....	4
6. CR .....	5
7. Parameters.....	5
8. Tally (Response) Data .....	11
9. Internal Errors .....	12
10. Projector Operation Modes .....	13
11. Source (Area).....	14
12. Commands.....	15
13. Appendix .....	72



※ Parameter is sent when tally (response) data is issued in response to a query (request for data.) There is no parameter for tally (response) data in response to a command.

### 3.2.2 Tally Data when Error Occurs

**Header** **ID** **SP** **Error Status** **CR**

**Header** : Indicates the beginning of the tally (response) data  
'@' (4 0 H)

**I D** : Identification number of Projector

**S P** : Indicates the separation between ID and Status (2 0 H)

**Error Status** : 'A00' (4 1 H 3 0 H 3 0 H)  
'A01' (4 1 H 3 0 H 3 1 H)  
'A02' (4 1 H 3 0 H 3 2 H)  
'A03' (4 1 H 3 0 H 3 3 H)  
'A04' (4 1 H 3 0 H 3 4 H)  
'A05' (4 1 H 3 0 H 3 5 H)  
'A07' (4 1 H 3 0 H 3 7 H)  
'A08' (4 1 H 3 0 H 3 8 H)  
'A09' (4 1 H 3 0 H 3 9 H)

**C R** : Indicates the end of the data (0 D H)

※For details on error status, refer to 8. Tally (Response) Data.

### 3.3 Internal Error Data Format (Projector → External Control)

**Header** **ID** **SP** **Internal Error Status** **SP** **Parameter** **SP** **Parameter** **SP** · · **CR**

**Header** : Indicates the beginning of the internal error data  
'&' (2 6 H)

**I D** : Identification of Projector

**S P** : Indicates the separation between ID and status, status and parameter, parameter and parameter (2 0 H)

**Internal Error Status** : 'E01' (4 5 H 3 0 H 3 1 H)  
'E02' (4 5 H 3 0 H 3 2 H)  
'E03' (4 5 H 3 0 H 3 3 H)  
'E04' (4 5 H 3 0 H 3 4 H)  
'E06' (4 5 H 3 0 H 3 6 H)  
'E07' (4 5 H 3 0 H 3 7 H)  
'E08' (4 5 H 3 0 H 3 8 H)

**C R** : Indicates the end of the data (0 D H)

※ For details on internal error status, refer to 9. Internal Errors.

## 4. HEADER

Indicates the beginning and type of communication data.

**4. 1 External Control → Projector**

Character	H E X	Definition
'!	2 1	Command to the Projector
'?'	3 F	Query (request for information) to the Projector

**4. 2 Projector → External Control**

Character	H E X	Definition
'@'	4 0	Tally (Response) data
'&'	2 6	Internal error data

# 5. ID

Numeric characters are used to identify an individual Projector when two or more Projector units are connected to a single control machine. Setting separate identification numbers for each Projector allows independent control of each Projector unit.

© Assignable ID numbers

- |             |             |
|-------------|-------------|
| '0' (3 0 H) | '8' (3 8 H) |
| '1' (3 1 H) | '9' (3 9 H) |
| '2' (3 2 H) | 'A' (4 1 H) |
| '3' (3 3 H) | 'B' (4 2 H) |
| '4' (3 4 H) | 'C' (4 3 H) |
| '5' (3 5 H) | 'D' (4 4 H) |
| '6' (3 6 H) | 'E' (4 5 H) |
| '7' (3 7 H) | 'F' (4 6 H) |

※ Factory set ID is '1' (31H).

ID number '0' (30H) should be used when assigning all connected Projector units for batch operations. This means that when assigning independent ID numbers to multiple units, 15 of the 16 assignable numbers (from '1' through 'F') can actually be used for registration.

Please note that tally (response) data is not returned from the projector when the global ID assignment function (0) is used.

# 6. CR

Indicates the end of each set of data. ( 0 D H )

## 7. PARAMETERS

There are four types of parameters:

1. Indicates the numeric value.
2. Indicates the MIN/MAX/DEFAULT level.
3. Indicates the ON/OFF status.
4. Special parameter.

### 7. 1 Numeric Value Parameter

Signed 2-byte hexadecimal code represented by 4 (byte) characters.  
Assignable range is between '8000' and '7FFF'.

Ex-1) The parameter indicating '20' (decimal):

Since '20' (decimal) is represented as '0014' in signed 2-byte hexadecimal,  
its parameter is:

' 0 0 1 4 ' ( 3 0 H 3 0 H 3 1 H 3 4 H )

Ex-2) The parameter to indicate '-2' (decimal):

Since '-2' (decimal) is represented as 'FFFE' in signed 2-byte hexadecimal,  
its parameter is:

' F F F E ' ( 4 6 H 4 6 H 4 6 H 4 5 H )

### 7. 2 MIN/MAX/DEFAULT Level Parameter

This parameter is used to request adjustable range data (e.g. Position) from the Projector.  
It is represented as

' \* ' ( 2 A H ) .

The Projector returns the tally (response) data in the order of minimum level, maximum level and the default level.

◎ Query data

' ? ' ID SP Command SP ' \* ' CR

◎ Tally (Response) data

' @ ' ID SP Normal Termination Status SP Min. SP Max. SP Default CR

※ This parameter is valid only with queries (request for data). To assign data on the Projector, use the numeric value parameter.

### 7. 3 ON/OFF Status Parameter

Indicates the ON/OFF status of items such as POWER or HIDE.

Character	H E X	Definition
'0'	3 0	O F F
'1'	3 1	O N

#### 7. 4 Special Parameters

Parameters other than those described in 7.1 to 7.3.

##### 7. 4. 1 ZOOM Wide/Tele, FOCUS +/- Parameter

Character	H E X	Definition
'0'	3 0	S T O P
'1'	3 1	S T A R T

##### 7. 4. 2 Menu Display Auto OFF Parameter

Character	H E X	Definition
'0'	3 0	N O
'1'	3 1	Y E S

##### 7. 4. 3 Transfer Rate Parameter

Character	H E X	Definition
'0'	3 0	9 6 0 0 b p s
'1'	3 1	1 9 2 0 0 b p s
'2'	3 2	3 8 4 0 0 b p s

##### 7. 4. 4 Decoder Parameter

Character	H E X	Definition
'0'	3 0	N T S C
'1'	3 1	N T S C 4. 4 3
'2'	3 2	P A L
'3'	3 3	S E C A M
'4'	3 4	A U T O

##### 7. 4. 5 Color Temperature Parameter

Character	H E X	Definition
'0'	3 0	L O W

' 1 '	3 1	M I D D L E
' 2 '	3 2	H I G H

**7. 4. 6 Input Select Parameter**

Character	H E X	Definition
' 0 '	3 0	Y / C
' 1 '	3 1	V I D E O
' 2 '	3 2	Y P B / B - Y P R / R - Y
' 3 '	3 3	C O M P 1 or RGB1
' 4 '	3 4	C O M P 2 or RGB2

**7. 4. 7 Projector Operation Mode Parameter**

Character	HEX	Definition
' 0000 '	30H 30H 30H 30H	Standby Mode
' 0001 '	30H 30H 30H 31H	Power ON Mode
' 0002 '	30H 30H 30H 32H	Cool-Down Mode
' 0004 '	30H 30H 30H 34H	Emergency Mode

**7. 4. 8 Text Mode Parameter**

Character	H E X	Definition
' 0 '	3 0	Normal
' 1 '	3 1	Text 1
' 2 '	3 2	Text 2

**7. 4. 9 Aspect Parameter**

Character	H E X	Definition
' 0 '	3 0	4 : 3
' 1 '	3 1	1 6 : 9

**7. 4. 1 0 Back Color Parameter**

Character	H E X	Definition
'0'	3 0	Black
'1'	3 1	Red
'2'	3 2	Green
'3'	3 3	Yellow
'4'	3 4	Blue
'5'	3 5	Magenta
'6'	3 6	Cyan

**7. 4. 1 1 ID Parameter**

Character	H E X	Definition
'0'	3 0	I D 0(global command for all projectors)
'1'	3 1	I D 1
'2'	3 2	I D 2
'3'	3 3	I D 3
'4'	3 4	I D 4
'5'	3 5	I D 5
'6'	3 6	I D 6
'7'	3 7	I D 7
'8'	3 8	I D 8
'9'	3 9	I D 9
'A'	4 1	I D 10
'B'	4 2	I D 11
'C'	4 3	I D 12
'D'	4 4	I D 13
'E'	4 5	I D 14
'F'	4 6	I D 15

**7. 4. 1 2 Clamp Parameter**

Character	H E X	Definition
' 0 '	3 0	B P
' 1 '	3 1	S T

**7. 4. 1 3 Shift Up/Down Parameter**

Character	H E X	Definition
' 0 '	3 0	S T O P
' 1 '	3 1	S T A R T

**7. 4. 1 4 Channel Parameter**

Character	H E X	Definition
' 0 1 '	30H 31H	Channel 1
' 0 2 '	30H 32H	Channel 2
' 0 3 '	30H 33H	Channel 3
' 0 4 '	30H 34H	Channel 4
' 0 5 '	30H 35H	Channel 5
' 0 6 '	30H 36H	Channel 6
' 0 7 '	30H 37H	Channel 7
' 0 8 '	30H 38H	Channel 8
' 0 9 '	30H 39H	Channel 9
' 0 A '	30H 41H	Channel 1 0
' F F '	46H 46H	Not Selected

**7. 4. 1 5 Switcher Number Parameter**

Character	HEX	Definition
'0001'	30H 30H 30H 31H	Switcher No. 1
'0002'	30H 30H 30H 32H	Switcher No. 2
'0003'	30H 30H 30H 33H	Switcher No. 3
'0004'	30H 30H 30H 34H	Switcher No. 4
'0005'	30H 30H 30H 35H	Switcher No. 5
'0006'	30H 30H 30H 36H	Switcher No. 6
'0007'	30H 30H 30H 37H	Switcher No. 7
'0008'	30H 30H 30H 38H	Switcher No. 8
'0009'	30H 30H 30H 39H	Switcher No. 9
'000A'	30H 30H 30H 41H	Switcher No. 10
'000B'	30H 30H 30H 42H	Switcher No. 11
'000C'	30H 30H 30H 43H	Switcher No. 12
'000D'	30H 30H 30H 44H	Switcher No. 13
'000E'	30H 30H 30H 45H	Switcher No. 14
'000F'	30H 30H 30H 46H	Switcher No. 15
'0010'	30H 30H 31H 30H	Switcher No. 16
'0011'	30H 30H 31H 31H	Switcher No. 17
'0012'	30H 30H 31H 32H	Switcher No. 18
'0013'	30H 30H 31H 33H	Switcher No. 19
'0014'	30H 30H 31H 34H	Switcher No. 20

# 8. TALLY (RESPONSE) DATA

The Projector will only accept and process data when the ID number included with the data coincides with the ID number registered to the Projector itself. (Except when ID = '0') If the received ID number matches the Projector's ID, it will return a response to the query from the external control unit. This response data is called "Tally (Response) Data". (However, when ID = '0', tally (response) data is not replied.)

The Tally (Response) Data is normally returned within 3 seconds after the data is received. There are some exceptions, however (e.g. POWER command)

After transmitting data, the external control unit cannot transmit subsequent data until the Tally (Response) Data is received. However, if Tally (Response) Data is not returned within 3 seconds after transmitting the data (there are some exceptions such as the POWER command), data transmission can be retried.

## 8. 1 Tally (Response) Data Status

### 8. 1. 1 Normal Termination Status

Character	H E X	Definition
' 0 '	30	Command received and processing terminated

### 8. 1. 2 Status when Error Occurs (Error Status)

Character	H E X	Definition
' A 0 0 '	41H 30H 30H	Command not supported
' A 0 1 '	41H 30H 31H	Invalid parameter
' A 0 2 '	41H 30H 32H	Parameter value exceeds operation range
' A 0 3 '	41H 30H 33H	Unclassified error
' A 0 4 '	41H 30H 34H	Unacceptable command in current mode or Unacceptable command with current setting
' A 0 5 '	41H 30H 35H	Unacceptable command with no signal
' A 0 7 '	41H 30H 37H	Unable to accept during scanning operation
' A 0 8 '	41H 30H 38H	Specified channel not set
' A 0 9 '	41H 30H 39H	Unable to find channel corresponding to switcher number

## 8. 2 Tally (Response) Data Parameter

The Tally (Response) Data Parameter is returned when the Tally (Response) Data is issued in response to a query (request for data). No parameter is returned when Tally (Response) Data issued in response to a command or when an error occurs.

# 9. INTERNAL ERRORS

Error data is returned to the external control unit when an error has occurred.

## 9. 1 Internal Error Data Status (Internal Error Status)

Character	HEX	Definition
'E01'	45H 30H 31H	Lamp did not light
'E02'	45H 30H 32H	Lamp life exceeds guaranteed time
'E03'	45H 30H 33H	IIC ACK error occurs
'E04'	45H 30H 34H	Filter cover on the bottom of the unit is displaced
'E06'	45H 30H 36H	Lamp suddenly goes out (Lamp Shut Down) while projecting (in Power ON mode)
'E07'	45H 30H 37H	Fan is locked
'E08'	45H 30H 38H	Internal temperature is too high.

## 9. 2 Internal Error Data Parameters

There are two parameters for Internal Error Data.

Header ID SP Internal Error Status SP

Parameter 1 SP Parameter 2 CR

Each parameter shows the slave address (Parameter 1) and Sub-Address (Parameter 2) when an IIC ACK error (Error status: 'E03') occurs.

The parameter type is "numeric value".

※ Two parameters are also returned when an internal errors other than IIC ACK errors occur. In this case, however, the parameter's numeric value has no meaning.

Ex) Internal error data when IIC ACK error occurs with Slave address 'A0H' and Sub-address of '1F20H':

'&' ID SP 'E03' SP '00A0' SP '1F20' CR

## 9. 3 Internal Error Data Reply Timing

When returning data, the Projector checks for internal error data. If such data exists, the internal error data is returned before the tally (response) data is transmitted. That is, if an internal error occurs, the Projector retains the internal error data (up to 6), returning it in order of precedence a request for tally (response) data is received. Once transmitted, internal error data is deleted from the Projector.

# 10. PROJECTOR OPERATION MODES

This section describes the Projector's four basic operation modes.

## 1 0 . 1 Standby Mode

The Projector enters this mode when it is plugged into an AC outlet and the MAIN POWER switch is turned ON.  
The lamp does not light and the fan does not operate.

## 1 0 . 2 Power ON Mode

This mode is engaged when the POWER ON command is received and processed normally in the Standby mode. The lamp lights and the fan starts rotating. Images can be projected in this mode.

## 1 0 . 3 Cool-Down Mode

This mode is engaged when the POWER OFF command is received and processed normally in the Power ON mode. The lamp goes out but the fan continues to rotate for a predetermined time (approx. 20 sec.) to cool down the lamp. Once the lamp has cooled down sufficiently, the fan stops and the unit automatically enters the Standby mode.

## 1 0 . 4 Emergency Mode

This mode is engaged when the projector malfunctions or is improperly operated. The lamp and the fan are shut down and the MAIN POWER switch is turned OFF. Non-operation status continues until the reset function is activated.

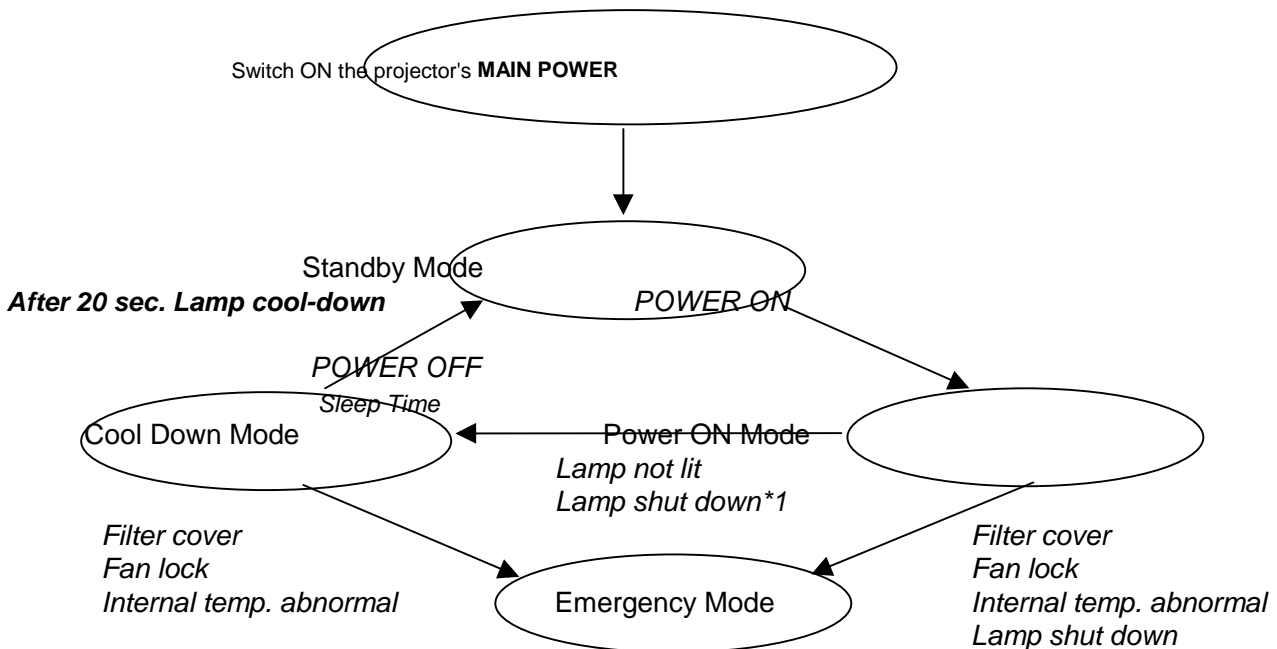

\*1: The G20 will go to Emergency Mode and M4000 will go to Standby Mode.

※ Note that the acceptance/non-acceptance condition of a command differs depending on the operation mode.

# 11. SOURCE (AREA)

The Projector incorporates an internal signal classification format that ensures that the images it projects correspond correctly to the type of signal being input. These classifications are called "Sources (Areas)", and each Source (Area) is assigned specified numbers. In the G20/M4000, there are an additional 10 User Sources (Areas) set aside for source registration at your discretion. A signal input from an external device is called an "Input Signal" or "Input Source".

## 1 1. 1 Projector Sources (Areas) and Source (Area) Numbers

Source	Source (Area) No. (Character)	Source (Area) No. (HEX)	Source	Source (Area) No. (Character)	Source (Area) No. (HEX)
NTSC (480i)	'0000'	30H 30H 30H 30H	SVGA 2	'000B'	30H 30H 30H 42H
PAL/SECAM	'0001'	30H 30H 30H 31H	MAC 16	'000C'	30H 30H 30H 43H
HDTV (720p)	'0002'	30H 30H 30H 32H	XGA 1	'000D'	30H 30H 30H 44H
SDTV (480p)	'0003'	30H 30H 30H 33H	XGA 2	'000E'	30H 30H 30H 45H
HDTV (1080i)	'0004'	30H 30H 30H 34H	MAC 19	'000F'	30H 30H 30H 46H
PC-98	'0005'	30H 30H 30H 35H	MAC 21	'0010'	30H 30H 31H 30H
VGA 1	'0006'	30H 30H 30H 36H	SXGA 1	'0011'	30H 30H 31H 31H
VGA 3	'0007'	30H 30H 30H 37H	SXGA 2	'0012'	30H 30H 31H 32H
MAC 13	'0008'	30H 30H 30H 38H	SXGA 3	'0013'	30H 30H 31H 33H
VGA VESA	'0009'	30H 30H 30H 39H	User Source	'0018' ~ '0021'	30H 30H 31H 38H ~ 30H 30H 32H 31H
SVGA 1	'000A'	30H 30H 30H 41H	No signal	'FFFF'	46H 46H 46H 46H

※The following source (area) types are considered **Video Sources (Areas)**:

NTSC (480i) PAL/SECAM HDTV (720p) SDTV (480p)  
HDTV (1080i)

The following source (area) types are considered **PC Sources (Areas) or Computer Sources (Areas)**:

PC-98 VGA 1 VGA 3 MAC 13 VGA VESA  
SVGA 1 SVGA 2 MAC 16 XGA 1 XGA 2 MAC 19  
MAC 21 SXGA 1 SXGA 2 SXGA 3

※ Note that the acceptance / non-acceptance of a command may differ depending on the Source (Area) actually registered on the Projector.

## 12. COMMANDS

This section describes the commands that can be used with the Projector.

- ◇ In the Communication Examples, the ID number registered on the Projector is represented as '1' (31H). This is the default setting.
- ◇ "CTRL" refers to transmissions from the external control unit and "DLA" refers to transmissions (Tally (Response) Data) from the Projector.
- ◇ "Reply Time" refers to the maximum time required between command reception and return of Tally (Response) Data. In other words, it refers to the maximum time that the external control unit must wait for the Tally (Response) Data.
- ◇ For details on the different parameters, refer to 7. Parameters.
- ◇ Acceptance or non-acceptance of a command in each operation mode is indicated by "◎" (accept) or "X" (does not accept).

## 12.1 HIDE : 'U 0 0' (5 5 H 3 0 H 3 0 H)

Definition : Controls video signal muting

Command : 'U 0 0' (5 5 H 3 0 H 3 0 H)  
 Parameter type : O N / O F F  
 Reply time : 3 seconds  
 Conditions :

Operation mode

Standby mode	Power ON mode	Cool-down mode	Emergency mode
x	⊙	x	x

### ⊙ Communication Examples

◇ To turn HIDE ON

```

CTRLR  '!' '1' SP 'U00' SP '1' CR
DLA    '@' '1' SP '0' CR
  
```

◇ When requesting current HIDE status (if HIDE status is ON)

```

CTRLR  '?' '1' SP 'U00' CR
DLA    '@' '1' SP '0' SP '1' CR
  
```

◇ When trying to change HIDE status in emergency mode (turn ON)

```

CTRLR  '!' '1' SP 'U00' SP '1' CR
DLA    '@' '1' SP 'A04' CR
  
```

## 12.2 Back Color : 'U 0 1' (5 5 H 3 0 H 3 1 H)

Definition : Controls the background color projected when Source (Area) has no signal

Command : 'U 0 1' (5 5 H 3 0 H 3 1 H)  
 Parameter type : Special parameter (Refer to 7.4.10 Back Color Parameter.)  
 Reply time : 3 seconds  
 Restrictions :

Operation mode

Standby mode	Power ON mode	Cool-down mode	Emergency mode
◎	◎	◎	×

### ◎ Communication Examples

◇ To specify "blue" as the background color

```

CTRLR  '! '1' SP 'U01' SP '5' CR
DLA    '@' '1' SP '0' CR
  
```

◇ When requesting background color data (if background color is set to magenta)

```

CTRLR  '? '1' SP 'U01' CR
DLA    '@' '1' SP '0' SP '2' CR
  
```

◇ When "blue" was specified for background color, but the projector was performing scanning operations

```

CTRLR  '! '1' SP 'U01' SP '5' CR
DLA    '@' '1' SP 'A07' CR
  
```

## 12.3 Horizontal Position : 'U02' (55H 30H 32H)

Definition : Adjusts the horizontal position

Command : 'U02' (55H 30H 32H)  
 Parameter type : Numeric, MAX/MIN/DEFAULT  
 Reply time : 3 seconds  
 Restrictions : None except when there is no Source (Area) signal

Operation mode

Standby mode	Power ON mode	Cool-down mode	Emergency mode
×	◎	×	×

### ◎ Communication Examples

◇ When specifying "30" (decimal) as the horizontal position

```

CTRLR '! '1' SP 'U02' SP '001E' CR
DLA      '@' '1' SP '0' CR
  
```

◇ When requesting current horizontal position data (if horizontal position is set to "-1")

```

CTRLR '? '1' SP 'U02' CR
DLA      '@' '1' SP '0' SP 'FFFF' CR
  
```

◇ When specifying the horizontal position, but the Source (Area) has no signal input

```

CTRLR '! '1' SP 'U02' SP '001E' CR
DLA      '@' '1' SP 'A05' CR
  
```

## 12.4 Vertical Position : 'U03' (55H 30H 33H)

Definition : Adjusts the vertical position

Command : 'U03' (55H 30H 33H)  
 Parameter type : Numeric, MAX/MIN/DEFAULT  
 Reply time : 3 seconds  
 Restrictions : None except when there is no Source (Area) signal

Operation mode

Standby mode	Power ON mode	Cool-down mode	Emergency mode
×	◎	×	×

### ◎ Communication Examples

◇ When specifying "5" (decimal) as the vertical position

```
CTLR '! '1' SP 'U03' SP '0005' CR
DLA '@' '1' SP '0' CR
```

◇ When requesting current vertical position data (if vertical position is set to "48" (decimal))

```
CTLR '?' '1' SP 'U03' CR
DLA '@' '1' SP '0' SP '0030' CR
```

◇ When specifying the vertical position, but an internal error occurs (IIC ACK error occurs at slave address: 00A0 (H), sub-address: 1003 (H))

```
CTLR '?' '1' SP 'U03' CR
DLA '&' '1' SP 'E03' SP '00A0' SP '1003' CR '@' '1' SP '0' SP '0030' CR
```

## 12.5 Phase : 'U04' (55H 30H 34H)

Definition : Adjusts the phase

Command : 'U04' (55H 30H 34H)  
 Parameter type : Numeric, MAX/MIN/DEFAULT  
 Reply time : 3 seconds  
 Restrictions : None except when there is no Source (Area) signal

Operation mode

Standby mode	Power ON mode	Cool-down mode	Emergency mode
×	⊙	×	×

### ⊙ Communication Examples

◇ When specifying "50" (decimal) as the phase adjust level

```

CTLR  '!' '1' SP 'U04' SP '0032' CR
DLA           '@' '1' SP '0' CR
  
```

◇ When requesting the current phase adjust level (if phase adjust level is set to "0" (decimal))

```

CTLR  '?' '1' SP 'U04' CR
DLA           '@' '1' SP '0' SP '0000' CR
  
```

## 12.6 Tracking : 'U05' (55H 30H 35H)

Definition : Adjusts tracking

Command : 'U05' (55H 30H 35H)  
 Parameter type : Numeric, MAX/MIN/DEFAULT  
 Reply time : 3 seconds  
 Restrictions : None except when there is no Source (Area) signal

Operation mode

Standby mode	Power ON mode	Cool-down mode	Emergency mode
×	⊙	×	×

### ⊙ Communication Examples

◇ When specifying "50" (decimal) as tracking adjust level

```

CTLR  '!' '1' SP 'U05' SP '0032' CR
DLA    '@' '1' SP '0' CR
  
```

◇ When requesting current tracking adjust level data (if tracking adjust level is set to "0" (decimal))

```

CTLR  '?' '1' SP 'U05' CR
DLA    '@' '1' SP '0' SP '0000' CR
  
```

## 12.7 Contrast : 'U06' (55H 30H 36H)

Definition : Adjusts the contrast

Command : 'U06' (55H 30H 36H)  
Parameter type : Numeric, MAX/MIN/DEFAULT  
Reply time : 3 seconds  
Restrictions : None except when there is no Source (Area) signal

Operation mode

Standby mode	Power ON mode	Cool-down mode	Emergency mode
x	⊙	x	x

### ⊙ Communication Examples

◇ When specifying "2" (decimal) as the contrast adjust level

```
CTLR '!' '1' SP 'U06' SP '0002' CR  
DLA '@' '1' SP '0' CR
```

◇ When requesting current contrast adjust level data (if contrast adjust level is set to "0" (decimal))

```
CTLR '?' '1' SP 'U06' CR  
DLA '@' '1' SP '0' SP '0000' CR
```

## 12.8 Brightness : 'U07' (55H 30H 37H)

Definition : Adjusts the brightness

Command : 'U07' (55H 30H 37H)  
Parameter type : Numeric, MAX/MIN/DEFAULT  
Reply time : 3 seconds  
Restrictions : None except when there is no Source (Area) signal

Operation mode

Standby mode	Power ON mode	Cool-down mode	Emergency mode
x	⊙	x	x

### ⊙ Communication Examples

◇ When specifying "-2" (decimal) as the brightness adjust level

```
CTLR  '!' '1' SP 'U07' SP 'FFFE' CR
DLA    '@' '1' SP '0' CR
```

◇ When requesting current brightness adjust level data (if brightness adjust level is set to "0" (decimal))

```
CTLR  '?' '1' SP 'U07' CR
DLA    '@' '1' SP '0' SP '0000' CR
```

## 12.9 Sharpness : 'U08' (55H 30H 38H)

Definition : Adjusts the sharpness

Command : 'U08' (55H 30H 38H)  
Parameter type : Numeric, MAX/MIN/DEFAULT  
Reply time : 3 seconds  
Restrictions : None except when there is no Source (Area) signal

Operation mode

Standby mode	Power ON mode	Cool-down mode	Emergency mode
x	⊙	x	x

### ⊙ Communication Examples

◇ When specifying "2" (decimal) as the sharpness

```
CTLR '!' '1' SP 'U08' SP '0002' CR  
DLA '@' '1' SP '0' CR
```

◇ When requesting current sharpness adjust level data (if sharpness adjust level is set to "7" (decimal))

```
CTLR '?' '1' SP 'U08' CR  
DLA '@' '1' SP '0' SP '0007' CR
```

## 12.10 Color : 'U09' (55H 30H 39H)

Definition : Adjusts the color

Command : 'U09' (55H 30H 39H)  
Parameter type : Numeric, MAX/MIN/DEFAULT  
Reply time : 3 seconds  
Restrictions : Video Sources (Areas) only

Operation mode

Standby mode	Power ON mode	Cool-down mode	Emergency mode
x	⊙	x	x

### ⊙ Communication Examples

◇ When specifying "-2" (decimal) as the color adjust level

```
CTLR '! '1' SP 'U09' SP 'FFFE' CR  
DLA '@' '1' SP '0' CR
```

◇ When requesting current color adjust level (if color adjust level is set to "0" (decimal))

```
CTLR '? '1' SP 'U09' CR  
DLA '@' '1' SP '0' SP '0000' CR
```

## 12.11 Tint : 'U0A' (55H 30H 41H)

Definition : Adjusts the tint

Command : 'U0A' (55H 30H 41H)  
 Parameter type : Numeric, MAX/MIN/DEFAULT  
 Reply time : 3 seconds  
 Restrictions : Source (Area) must be NTSC, EDTV II or HDTV

Operation mode

Standby mode	Power ON mode	Cool-down mode	Emergency mode
×	⊙	×	×

### ⊙ Communication Examples

◇ When specifying "-2" (decimal) as the tint adjust level

```

CTLR  '!' '1' SP 'U0A' SP 'FFFE' CR
DLA           '@' '1' SP '0' CR
  
```

◇ When requesting current tint adjust level data (if tint adjust level is set to "0" (decimal))

```

CTLR  '?' '1' SP 'U0A' CR
DLA           '@' '1' SP '0' SP '0000' CR
  
```

## 12.12 Color Temperature : 'U 0 B' ( 5 5 H 3 0 H 4 2 H )

Definition : Adjusts the color temperature

Command : 'U 0 B' ( 5 5 H 3 0 H 4 2 H )  
 Parameter type : Special parameter (Refer to 7.4.5 Color Temperature Parameter.)  
 Reply time : 3 seconds  
 Restrictions : None except when there is no Source (Area) signal

Operation mode

Standby mode	Power ON mode	Cool-down mode	Emergency mode
×	⊙	×	×

### ⊙ Communication Examples

◇ When specifying "MIDDLE" as the color temperature

```
CTLR  '!' '1' SP 'U0B' SP '1' CR
DLA    '@' '1' SP '0' CR
```

◇ When requesting current color temperature data (if color temperature is set to "LOW")

```
CTLR  '?' '1' SP 'U0B' CR
DLA    '@' '1' SP '0' SP '0' CR
```

## 12.13 R-Gain : 'U0C' (55H 30H 43H)

Definition : Adjusts the R-gain

Command : 'U0C' (55H 30H 43H)  
 Parameter type : Numeric, MAX/MIN/DEFAULT  
 Reply time : 3 seconds  
 Restrictions : Computer Sources (Areas) only

Operation mode

Standby mode	Power ON mode	Cool-down mode	Emergency mode
×	⊙	×	×

### ⊙ Communication Examples

- ◇ When specifying "-2" (decimal) as the R-gain adjust level

```

CTLR  '!' '1' SP 'U0C' SP 'FFFE' CR
DLA           '@' '1' SP '0' CR
  
```

- ◇ When requesting current R-gain adjust level data (if R-gain adjust level is set to "0" (decimal))

```

CTLR  '?' '1' SP 'U0C' CR
DLA           '@' '1' SP '0' SP '0000' CR
  
```

## 12.14 G-Gain : 'U0D' (55H 30H 44H)

Definition : Adjusts the G-gain

Command : 'U0D' (55H 30H 44H)  
 Parameter type : Numeric, MAX/MIN/DEFAULT  
 Reply time : 3 seconds  
 Restrictions : Computer Sources (Areas) only

Operation mode

Standby mode	Power ON mode	Cool-down mode	Emergency mode
×	⊙	×	×

### ⊙ Communication Examples

◇ When specifying "-2" (decimal) as the G-gain adjust level

```

CTLR  '!' '1' SP 'U0D' SP 'FFFE' CR
DLA           '@' '1' SP '0' CR
  
```

◇ When requesting current G-gain adjust level data (if G-gain adjust level is set to "0" (decimal))

```

CTLR  '?' '1' SP 'U0D' CR
DLA           '@' '1' SP '0' SP '0000' CR
  
```

## 12.15 B-Gain : 'U0E' (55H 30H 45H)

Definition : Adjusts the B-gain

Command : 'U0E' (55H 30H 45H)  
 Parameter type : Numeric, MAX/MIN/DEFAULT  
 Reply time : 3 seconds  
 Restrictions : Computer Sources (Areas) only

Operation mode

Standby mode	Power ON mode	Cool-down mode	Emergency mode
×	⊙	×	×

### ⊙ Communication Examples

◇ When specifying "-2" (decimal) as the B-gain adjust level

```

CTLR  '!' '1' SP 'U0E' SP 'FFFE' CR
DLA           '@' '1' SP '0' CR
  
```

◇ When requesting current B-gain adjust level data (if B-gain adjust level is set to "0" (decimal))

```

CTLR  '?' '1' SP 'U0E' CR
DLA           '@' '1' SP '0' SP '0000' CR
  
```

## 12.16 POWER : 'U O F' (5 5 H 3 0 H 4 6 H)

Definition : Controls the power

Command : 'U O F' (5 5 H 3 0 H 4 6 H)  
 Parameter type : O N / O F F  
 Reply time : POWER O N transmission 6 5 seconds (\* 1)  
                   POWER O F F transmission 3 seconds (\* 2)  
 Restrictions : No query

Operation mode

Standby mode	Power ON mode	Cool-down mode	Emergency mode
◎	◎	×	×

### ◎ Communication Examples

◇ When turning the Projector's power ON

```
CTLR  '!' '1' SP 'U0F' SP '1' CR
DLA    '@' '1' SP '0' CR
```

\* 1

When the POWER ON command is received, the Projector returns the Tally (Response) Data after completing all the POWER ON processing operations (lighting lamp, rotating fan, transmitting data, etc.). These operations can take up to a maximum of about 65 seconds (if it takes the lamp a long time to light up).

In most cases, the Tally (Response) Data should be returned within 35 to 40 seconds.

\* 2

When the POWER OFF command is received, the Projector enters the cool-down mode (DLA-G20: for about 120 seconds, DLA-M4000L: for about 20 seconds) to allow the lamp to cool (DLA-G20: for about 120 seconds, DLA-M4000L: for about 10 minutes).

After cool-down mode is completed, the Projector automatically enters the stand-by mode. (For operation modes, refer to 10. Projector Operation Modes.)

Since the POWER ON command cannot be accepted in the Cool-Down mode, first query (issue a request for data) the operation mode to confirm that the Projector is in the Standby mode, then transmit the POWER ON command to turn on the Projector again. (For the command to request the current operation mode, refer to 12.41 Operation Mode Query.)

## 12.17 MENU Auto OFF : 'U 1 0' (5 5 H 3 1 H 3 0 H)

Definition : Controls the display menu auto-off function

Command : 'U 1 0' (5 5 H 3 1 H 3 0 H)

Parameter type : Special parameter (Refer to 7.4.2 Menu Display Auto OFF Parameter.)

Reply time : 3 seconds

Restrictions :

Operation mode

Standby mode	Power ON mode	Cool-down mode	Emergency mode
◎	◎	◎	×

### ◎ Communication Examples

◇ When specifying that the menu display is turned off automatically

```

CTRLR  '! '1' SP 'U10' SP '1' CR
DLA    '@' '1' SP '0' CR
    
```

◇ When requesting the current menu display auto-off setting (if menu display does not turn off automatically)

```

CTRLR  '? '1' SP 'U10' CR
DLA    '@' '1' SP '0' SP '0' CR
    
```

## 12.18 Line Display : 'U 1 1' (5 5 H 3 1 H 3 1 H)

Definition : Sets the line source (area) display

Command : 'U 1 1' (5 5 H 3 1 H 3 1 H)  
Parameter type : ON/OFF  
Reply time : 3 seconds  
Restrictions :

Operation mode

Standby mode	Power ON mode	Cool-down mode	Emergency mode
◎	◎	◎	×

### ◎ Communication Examples

◇ When setting the line display to OFF

```
CTLR '! '1' SP 'U11' SP '0' CR
DLA '@' '1' SP '0' CR
```

◇ When requesting the current line display setting (if the line display is set to ON)

```
CTLR '? '1' SP 'U11' CR
DLA '@' '1' SP '0' SP '1' CR
```

## 12.19 Sleep Time : 'U 1 2' (5 5 H 3 1 H 3 2 H)

Definition : Sets the sleep time

Command : 'U 1 2' (5 5 H 3 1 H 3 2 H)  
 Parameter type : (\*)  
 Reply time : 3 seconds  
 Restrictions :

Operation mode

Standby mode	Power ON mode	Cool-down mode	Emergency mode
◎	◎	◎	×

The "Sleep time" function automatically turns off the projector power if the no-signal status continues for a specified time.

\* Available parameters

Sleep time can be set to any of the following:

10 min., 20 min., 30 min., 60 min., and 0 min.

When the above times are represented as numerical parameters:

	Character	H E X
1 0 min.	' 0 0 0 A '	30H 30H 30H 41H
2 0 min.	' 0 0 1 4 '	30H 30H 31H 34H
3 0 min.	' 0 0 1 E '	30H 30H 31H 45H
6 0 min.	' 0 0 3 C '	30H 30H 33H 43H
0 min.	' 0 0 0 0 '	30H 30H 30H 30H

The sleep time function is disabled when the time is set to "0 min".

◎ Tally (Response) data format to current sleep time query

' @ ' ' 1 ' S P Normal Termination Status

S P Parameter 1 S P Parameter 2 CR

Parameter 1 : Indicates the sleep time specified  
(Refer to "Available parameters")

Parameter 2 : Indicates the remaining sleep time.  
Parameter type is numeric.

◎ Communication Examples

◇ When specifying "30 min." as the sleep time

```
CTLR '! '1' SP 'U12' SP '001E' CR
DLA '@' '1' SP '0' CR
```

◇ When requesting the current sleep time setting (if the sleep time is set to "10 min." and the remaining time is 3 min.)

```
CTLR '?' '1' SP 'U12' CR
DLA '@' '1' SP '0' SP '000A' SP '0003' CR
```

## 12.20 ZOOM W : 'U 1 3' (5 5 H 3 1 H 3 3 H)

Definition : Enlarges the screen size

Command : 'U 1 3' (5 5 H 3 1 H 3 3 H)

Parameter type : Special parameter (Refer to 7.4.1 ZOOM W/T FOCUS +/- Parameter.)

Reply time : 3 seconds

Restrictions : No query

Operation mode

Standby mode	Power ON mode	Cool-down mode	Emergency mode
x	⊙	x	x

### ⊙ Communication Examples

```
CTLR  '!' '1' SP 'U13' SP '1' CR          '!' '1' SP 'U13' SP '0' CR
DLA    '@' '1' SP '0' CR                    '@' '1' SP '0' CR
```

※ Be sure to transmit the STOP command after transmitting the START command.

## 12.21 ZOOM T : 'U 1 4' (5 5 H 3 1 H 3 4 H)

Definition : Reduces the screen size

Command : 'U 1 4' (5 5 H 3 1 H 3 4 H)

Parameter type : Special parameter (Refer to 7.4.1 ZOOM W/T FOCUS +/- Parameter.)

Reply time : 3 seconds

Restrictions : No query

Operation mode

Standby mode	Power ON mode	Cool-down mode	Emergency mode
×	⊙	×	×

### ⊙ Communication Examples

```

CTLR  '!' '1' SP 'U14' SP '1' CR           '!' '1' SP 'U14' SP '0' CR
DLA    '@' '1' SP '0' CR                     '@' '1' SP '0' CR
  
```

※ Be sure to transmit the STOP command after transmitting the START command.

## 12.22 FOCUS + : 'U 1 5' (5 5 H 3 1 H 3 5 H)

Definition : Moves the focal point forward

Command : 'U 1 5' (5 5 H 3 1 H 3 5 H)

Parameter type : Special parameter (Refer to 7.4.1 ZOOM W/T FOCUS +/- Parameter.)

Reply time : 3 seconds

Restrictions : No query

Operation mode

Standby mode	Power ON mode	Cool-down mode	Emergency mode
x	⊙	x	x

### ⊙ Communication Examples

```
CTLR  '!' '1' SP 'U15' SP '1' CR          '!' '1' SP 'U15' SP '0' CR
DLA    '@' '1' SP '0' CR                    '@' '1' SP '0' CR
```

※ Be sure to transmit the STOP command after transmitting the START command.

## 12.23 FOCUS - : 'U 1 6' (5 5 H 3 1 H 3 6 H)

Definition : Moves the focal point back

Command : 'U 1 6' (5 5 H 3 1 H 3 6 H)

Parameter type : Special parameter (Refer to 7.4.1 ZOOM W/T FOCUS +/- Parameter. )

Reply time : 3 seconds

Restrictions : No query

Operation mode

Standby mode	Power ON mode	Cool-down mode	Emergency mode
x	⊙	x	x

⊙ Communication Examples

```
CTLR  '!' '1' SP 'U16' SP '1' CR          '!' '1' SP 'U16' SP '0' CR
DLA    '@' '1' SP '0' CR                    '@' '1' SP '0' CR
```

※ Be sure to transmit the STOP command after transmitting the START command.

## 12.24 Right/Left Reverse : 'U 1 7' (5 5 H 3 1 H 3 7 H)

Definition : Reverses the image horizontally

Command : 'U 1 7' (5 5 H 3 1 H 3 7 H)  
 Parameter type : O N / O F F  
 Reply time : 3 seconds  
 Restrictions :

Operation mode

Standby mode	Power ON mode	Cool-down mode	Emergency mode
⊙	⊙	⊙	×

### ⊙ Communication Examples

◇ When reversing the image horizontally (Right /Left reverse)

```

CTLR  '!' '1' SP 'U17' SP '1' CR
DLA    '@' '1' SP '0' CR
  
```

◇ When requesting the current R/L reverse setting (if the image is not reversed horizontally)

```

CTLR  '?' '1' SP 'U17' CR
DLA    '@' '1' SP '0' SP '0' CR
  
```

## 12.25 Top/Bottom Invert : 'U 1 8' (5 5 H 3 1 H 3 8 H)

Definition : Inverts the image vertically

Command : 'U 1 8' (5 5 H 3 1 H 3 8 H)  
 Parameter type : O N / O F F  
 Reply time : 3 seconds  
 Restrictions :

Operation mode

Standby mode	Power ON mode	Cool-down mode	Emergency mode
◎	◎	◎	×

### ◎ Communication Examples

◇ When inverting the image vertically (Top/Bottom invert)

```

CTLR  '!' '1' SP 'U18' SP '1' CR
DLA    '@' '1' SP '0' CR
  
```

◇ When requesting the current Top/Bottom invert setting (if the image is not inverted vertically)

```

CTLR  '?' '1' SP 'U18' CR
DLA    '@' '1' SP '0' SP '0' CR
  
```

## 12.26 Decoder : 'U 1 9' (5 5 H 3 1 H 3 9 H)

Definition : Selects the color TV broadcast system

Command : 'U 1 9' (5 5 H 3 1 H 3 9 H)  
 Parameter type : Special parameter (Refer to 7.4.4 Decoder Parameter.)  
 Reply time : 3 seconds  
 Restrictions : None except when there is no Source (Area) signal

Operation mode

Standby mode	Power ON mode	Cool-down mode	Emergency mode
×	⊙	×	×

### ⊙ Communication Examples

◇ When selecting "NTSC" as the broadcast system

```

CTLR  '!' '1' SP 'U19' SP '0' CR
DLA           '@' '1' SP '0' CR
  
```

◇ When requesting the current broadcast system setting (if the broadcast system is set to PAL)

```

CTLR  '?' '1' SP 'U19' CR
DLA           '@' '1' SP '0' SP '2' CR
  
```

## 12.27 Input Select : 'U 1 A' (5 5 H 3 1 H 4 1 H)

Definition : Selects the video input terminals

Command : 'U 1 A' (5 5 H 3 1 H 4 1 H)  
 Parameter type : Special parameter (Refer to 7.4.6 Input Select Parameter.)  
 Reply time : 3 seconds  
 Restrictions :

Operation mode

Standby mode	Power ON mode	Cool-down mode	Emergency mode
×	◎	×	×

### ◎ Communication Examples

◇ When selecting "COMP 1" as the video input

```

CTRLR  '!' '1' SP 'U1A' SP '3' CR
DLA    '@' '1' SP '0' CR
  
```

◇ When requesting the current video input setting (if the video input is set to PAL)

```

CTRLR  '?' '1' SP 'U1A' CR
DLA    '@' '1' SP '0' SP '1' CR
  
```

## 12.28 Transfer Rate : 'U 1 B' (5 5 H 3 1 H 4 2 H)

Definition : Controls the transfer rate for RS-232C

Command : 'U 1 B' (5 5 H 3 1 H 4 2 H)  
 Parameter type : Special parameter (Refer to 7.4.3 Transfer Rate Parameter.)  
 Reply time : 3 seconds  
 Restrictions :

Operation mode

Standby mode	Power ON mode	Cool-down mode	Emergency mode
⊙	⊙	⊙	×

※ After this command has been received and processed, the Tally (Response) Data is returned at the current speed setting. The new transfer rate takes effect after return of the Tally (Response) Data.

### ⊙ Communication Examples

◇ When changing the transfer rate to "19200 bps" from the current setting of "9600 bps"

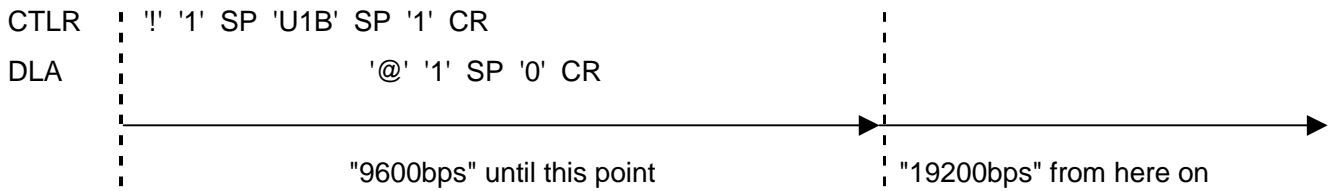

※ The default transfer rate setting is "9600bps".

## 12.29 Lamp Time : 'U 1 C' (5 5 H 3 1 H 4 3 H)

Definition : Reset/check the lamp operation

Command : 'U 1 C' (5 5 H 3 1 H 4 3 H)  
 Parameter type : (\*)  
 Reply time : 3 seconds  
 Restrictions :

Operation mode

△ When resetting

Standby mode	Power ON mode	Cool-down mode	Emergency mode
◎	×	×	×

△ When requesting current time

Standby mode	Power ON mode	Cool-down mode	Emergency mode
◎	◎	◎	×

◎ Data Format

△ Reset data format

'!' '1' SP 'U 1 C' SP Reset Parameter CR

(\*) Reset parameter

Character	HEX
' [ ( ) ] '	5 B H 2 8 H 2 9 H 5 D H

※ Never issue the Reset command unless the lamp has been replaced with a new one.

△ Tally (Response) data format when requesting current time

'@' '1' SP Normal Termination Status SP Parameter 1 SP Parameter 2 CR

(\*) Parameter 1

The Projector has an incremental counter which counts in four minute increments. Parameter 1 shows this counter value. The parameter type is "numeric".

Actual lamp operating time is obtained by converting the Parameter 1 value into signed 2-byte binary hexadecimal and dividing it by 15.

( \* ) Parameter 2

Parameter 2 shows whether the lamp replacement time is close or not, based on the following calculation:

$$(\text{Lamp service life} - 100 \text{ hours}) \leq \text{Lamp operating time} < \text{Lamp service life}$$

	Character	HEX
Lamp replacement time not close or Lamp life exceeded	' 0 '	3 0 H
Lamp replacement time close	' 1 '	3 1 H

© Communication Examples

◇ When requesting the current lamp operating time (if the lamp operating time is 150 hours)

```
CTLR  '?' '1' SP 'U1C' CR
DLA   '@' '1' SP '0' SP '08CA' SP '0' CR
```

**12.30 ID : 'U 1 D' (5 5 H 3 1 H 4 4 H)**

Definition : Sets the ID for the Projector

Command : 'U 1 D' (5 5 H 3 1 H 4 4 H)  
 Parameter type : Special parameter (Refer to 7.4.11 ID Parameter.)  
 Reply time : 3 seconds  
 Restrictions : No query

Operation mode

Standby mode	Power ON mode	Cool-down mode	Emergency mode
◎	◎	◎	×

※ When this command is received processed correctly, the Tally (Response) Data is returned with the changed ID number.

◎ Communication Examples

◇ When changing the ID to '7' from the current setting of '1'

```

CTLR '! '1' SP 'U1D' SP '7' CR
DLA      '@' '7' SP '0' CR
    
```

↑  
Tally (Response) data is returned with specified ID no.

## 12.31 BASS : 'U 1 E' ( 5 5 H 3 1 H 4 5 H )

Definition : Adjusts the audio bass level (G20 Series only)

Command : 'U 1 E' ( 5 5 H 3 1 H 4 5 H )  
 Parameter type : Numeric, M A X / M I N / D E F A U L T  
 Reply time : 3 seconds  
 Restrictions :

Operation mode

Standby mode	Power ON mode	Cool-down mode	Emergency mode
×	◎	×	×

### ◎ Communication Example

◇ When setting the BASS adjust level to "3"

```

CTLR  '!' '1' SP 'U1E' SP '0003' CR
DLA           '@' '1' SP '0' CR
  
```

◇ When requesting the current BASS adjust level setting (if the BASS level is set to "-1")

```

CTLR  '?' '1' SP 'U1E' CR
DLA           '@' '1' SP '0' SP 'FFFF' CR
  
```

## 12.32 TREBLE : 'U 1 F' (5 5 H 3 1 H 4 6 H)

Definition : Adjusts the audio treble level (G20 Series only)

Command : 'U 1 F' (5 5 H 3 1 H 4 6 H)  
 Parameter type : Numeric, M A X / M I N / D E F A U L T  
 Reply time : 3 seconds  
 Restrictions :

Operation mode

Standby mode	Power ON mode	Cool-down mode	Emergency mode
×	◎	×	×

### ◎ Communication Example

◇ When setting the TREBLE adjust level to "3"

```

CTLR  '!' '1' SP 'U1F' SP '0003' CR
DLA           '@' '1' SP '0' CR
  
```

◇ When requesting the current TREBLE adjust level setting (if the TREBLE level is set to "-1")

```

CTLR  '?' '1' SP 'U1F' CR
DLA           '@' '1' SP '0' SP 'FFFF' CR
  
```

## 12.33 Volume : 'U20' (55H 32H 30H)

Definition : Adjusts the audio volume level (G20 Series only)

Command : 'U20' (55H 32H 30H)  
 Parameter type : Numeric, MAX/MIN/DEFAULT  
 Reply time : 3 seconds  
 Restrictions : None except when there is no Source (Area) signal

### Operation mode

Standby mode	Power ON mode	Cool-down mode	Emergency mode
×	⊙	×	×

### ⊙ Communication Example

◇ When setting the volume adjust level to "30"

```
CTLR  '!' '1' SP 'U20' SP '001E' CR
DLA    '@' '1' SP '0' CR
```

◇ When requesting the current volume adjust level setting (if the volume level is set to "5")

```
CTLR  '?' '1' SP 'U20' CR
DLA    '@' '1' SP '0' SP '0005' CR
```

## 12.34 Audio Muting : 'U 2 1' (5 5 H 3 2 H 3 1 H)

Definition : Command to control the audio muting (G20 Series only)

Command : 'U 2 1' (5 5 H 3 2 H 3 1 H)  
 Parameter type : O N / O F F  
 Reply time : 3 seconds  
 Restrictions : None except when there is no Source (Area) signal

Operation mode

Standby mode	Power ON mode	Cool-down mode	Emergency mode
×	◎	×	×

### ◎ Communication Example

◇ When muting the output sound

```

CTLR  '!' '1' SP 'U21' SP '1' CR
DLA    '@' '1' SP '0' CR
  
```

◇ When requesting the current audio muting status (if the audio muting is set to OFF)

```

CTLR  '?' '1' SP 'U21' CR
DLA    '@' '1' SP '0' SP '0' CR
  
```

## 12.35 Quick Alignment : 'U 2 A' (5 5 H 3 2 H 4 1 H)

Definition : Controls the quick alignment function

Command : 'U 2 A' (5 5 H 3 2 H 4 1 H)  
 Parameter type : (\*)  
 Reply time : 3 seconds  
 Restrictions : Computer Sources (Areas) only

Operation mode

Standby mode	Power ON mode	Cool-down mode	Emergency mode
x	⊙	x	x

\* Quick Alignment Parameter  
Use only ON parameter for ON/OFF.

◇ Quick alignment parameter

	Character	H E X
O N	' 1 '	3 1 H

The Projector performs quick alignment processing after returning Normal Termination Status Tally (Response) data. Therefore, requests to check the quick alignment status should be sent from the control unit at a fixed interval (more than 1 second) after transmitting the ON command. Once quick alignment processing is confirmed, transmit the next command. If the next command is transmitted during quick alignment processing (before confirming completion of quick alignment), the Projector may malfunction.

**Never transmit any commands other than the quick alignment query during quick alignment processing operations.**

\* Tally (Response) data to the query

◇ Tally (Response) data format against query

'@ ' 
 ' 1 ' 
 SP 
 Normal Termination

Status 
 SP 
 Parameter 
 CR

◇ Tally (Response) data parameters to query

	Character	H E X	Definition
Normal termination	' 0 '	3 0 H	Quick alignment processing completed correctly (End)
Failed	' 1 '	3 1 H	Quick alignment processing failed (End)
In processing	' 2 '	3 2 H	Quick alignment is under processing (during processing)

© Communication Examples

More than 1 sec.

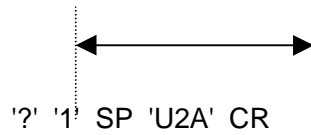

CTLR '! '1' SP 'U2A' SP '1' CR  
DLA '@' '1' SP '0' CR

More than 1 sec.

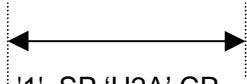

(CTLR) '?' '1' SP 'U2A' CR  
(DLA) '@' '1' SP '0' SP '2' CR

More than 1 sec.

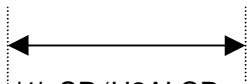

(CTLR) '?' '1' SP 'U2A' CR  
(DLA) '@' '1' SP '0' SP '2' CR

Possible to transmit next command

(CTLR)  
(DLA) '@' '1' SP '0' SP '0' CR

## 12.36 Text Mode : 'U 2 C' (5 5 H 3 2 H 4 3 H)

Definition : Controls the legibility of screen text

Command : 'U 2 C' (5 5 H 3 2 H 4 3 H)  
 Parameter type : Special parameter (Refer to 7.4.8 Text Mode Parameter.)  
 Reply time : 3 seconds  
 Restrictions : Computer Sources (Areas) only. Does not include SXGA1,  
SXGA2, SXGA3. Resize function must be set to ON.

Operation mode

Standby mode	Power ON mode	Cool-down mode	Emergency mode
×	⊙	×	×

### ⊙ Communication Examples

◇ When setting the text mode to "Normal"

```

CTRLR  '!' '1' SP 'U2C' SP '0' CR
DLA    '@' '1' SP '0' CR
  
```

◇ When requesting current text mode setting (if the text mode is set to "Text 1")

```

CTRLR  '?' '1' SP 'U2C' CR
DLA    '@' '1' SP '0' SP '1' CR
  
```

## 12.37 Resize : 'U 2 D' (5 5 H 3 2 H 4 4 H)

Definition : Controls expanded image

Command : 'U 2 D' (5 5 H 3 2 H 4 4 H)  
 Parameter type : O N / O F F  
 Reply time : 3 seconds  
 Restrictions : Computer Sources (Areas) only. Does not include SXGA1,  
SXGA2, SXGA3

Operation mode

Standby mode	Power ON mode	Cool-down mode	Emergency mode
x	⊙	x	x

### ⊙ Communication Examples

◇ When setting the resize function to ON

```

CTRLR  '!' '1' SP 'U2D' SP '1' CR
DLA    '@' '1' SP '0' CR
  
```

◇ When requesting the current resize function setting (if the resize function is set to OFF)

```

CTRLR  '?' '1' SP 'U2D' CR
DLA    '@' '1' SP '0' SP '0' CR
  
```

## 12.38 Aspect Change : ' U 2 E ' ( 5 5 H 3 2 H 4 5 H )

Definition : Controls the aspect ratio of the projected image

Command : ' U 2 E ' ( 5 5 H 3 2 H 4 5 H )  
 Parameter type : Special parameter (Refer to 7.4.9 Aspect Parameter.)  
 Reply time : 3 seconds  
 Restrictions : Video Sources (Areas) only.

Operation mode

Standby mode	Power ON mode	Cool-down mode	Emergency mode
×	◎	×	×

### ◎ Communication Examples

◇ When setting the aspect ratio to "4:3"

```

CTLR  '!' '1' SP 'U2E' SP '0' CR
DLA   '@' '1' SP '0' CR
  
```

◇ When requesting the current aspect ratio setting (if the aspect ratio is set to "16:9")

```

CTLR  '?' '1' SP 'U2E' CR
DLA   '@' '1' SP '0' SP '1' CR
  
```

## 12.39 Source (Area) Assignment : 'U 2 F' (5 5 H 3 2 H 4 6 H)

Definition : Specifies Source (Area) (for each input)

Command : 'U 2 F' (5 5 H 3 2 H 4 6 H)  
 Parameter type : (\*)  
 Reply time : 3 seconds  
 Restrictions :

Operation mode

Standby mode	Power ON mode	Cool-down mode	Emergency mode
◎	◎	×	×

**\* Source (Area) assignment data format**

◇ When specifying with command

['!'] ['1'] SP ['U 2 F'] SP

**Parameter 1** SP **Parameter 2** CR

**Parameter 1 : Input source information**

Indicates Source (Area) information for the input terminal specified for Source (Area). (Refer to 7.4.6 Input Select Parameter).

**Parameter 2 : Source information**

Indicates the Source (Areas) setting. The available parameters are those listed in 11.1 Projector Sources (Areas) and Source (Area) Numbers except for "No signal", with "AUTO" added. (Refer to 12.39.1 Source (Area) Assignment Parameter.)

◇ When requesting current source

['?'] ['1'] SP ['U 2 F'] SP **Parameter** CR

**Parameter : Input source information**

Indicates Source (Area) information for the input terminal specified for Source (Area). Refer to 7.4.6 Input Select Parameter.

◎ Tally (Response) data format to query

['@'] ['1'] SP Normal Termination

Status SP **Parameter** CR

**Parameter : Source (Area) information**

Indicates the Source (Area) information assigned to the "Input source specified for requesting current data". (Refer to 12.39.1 Source (Area) Assignment Parameter.)

※ When "AUTO" is assigned for Source (Area), the Projector automatically analyzes the input signal to select the most appropriate Source (Area).

※ When Source (Area) is set to anything other than "AUTO", and no signal is input, the Source (Area) is set to "No signal". The Source (Area) assignment command is used only for requesting current

Source (Area) setting status.

For the information on the Source (Area) actually selected on the Projector, use 12.42 Source (Area) Query.

© Source (Area) items actually assigned on the Projector

△ When "AUTO" is specified with the Source (Area) assignment command

Any item listed in 11.1 Projector Sources (Areas) and Source (Area) Numbers.

△ When anything other than "AUTO" is specified with the Source (Area) assignment command

Any item assigned for Source (Area) or "No signal"

※ To obtain the information about Source (Area) actually assigned on the PROJECTOR, use the 12.42Source (Area) Query.

12. 39. 1 Source (Area) assignment parameters

Source (Area)	Source (Area) No. (Character)	Source (Area) No. (HEX)	Source (Area)	Source (Area) No. (Character)	Source (Area) No. (HEX)
NTSC(480i)	' 0 0 0 0 '	30H 30H 30H 30H	SVGA2	' 0 0 0 B '	30H 30H 30H 42H
PAL / SECAM	' 0 0 0 1 '	30H 30H 30H 31H	MAC16	' 0 0 0 C '	30H 30H 30H 43H
HDTV(720p)	' 0 0 0 2 '	30H 30H 30H 32H	XGA1	' 0 0 0 D '	30H 30H 30H 44H
SDTV(480p)	' 0 0 0 3 '	30H 30H 30H 33H	XGA2	' 0 0 0 E '	30H 30H 30H 45H
HDTV(1080i)	' 0 0 0 4 '	30H 30H 30H 34H	MAC19	' 0 0 0 F '	30H 30H 30H 46H
PC-98	' 0 0 0 5 '	30H 30H 30H 35H	MAC21	' 0 0 1 0 '	30H 30H 31H 30H
VGA1	' 0 0 0 6 '	30H 30H 30H 36H	SXGA1	' 0 0 1 1 '	30H 30H 31H 31H
VGA3	' 0 0 0 7 '	30H 30H 30H 37H	SXGA2	' 0 0 1 2 '	30H 30H 31H 32H
MAC13	' 0 0 0 8 '	30H 30H 30H 38H	SXGA3	' 0 0 1 3 '	30H 30H 31H 33H
VGA VESA	' 0 0 0 9 '	30H 30H 30H 39H	USER SOURCE	' 0 0 1 8 '~ ' 0 0 2 1 '~	30H 30H 31H 38H ~ 30H 30H 32H 31H
SVGA1	' 0 0 0 A '	30H 30H 30H 41H	AUTO	' 0 0 0 A '	30H 30H 30H 41H

© Communication Examples

◇ When specifying "VGA3" for COMP1/RGB1

```
CTLR  '! '1' SP 'U2F' SP '3' SP '0007' CR
DLA      '@' '1' SP '0' CR
```

◇ When requesting current Source (Area) setting for VIDEO (if it is set to "AUTO")

```
CTLR  '? '1' SP 'U2F' SP '1' CR
DLA      '@' '1' SP '0' SP '00A0' CR
```

※ Note that the types of Sources (Areas) that can be assigned differ depending on the input terminals. For information on the relationship between input terminals and Source (Area) settings, refer to 12.39.2 Input Terminals and Assignable Sources (Areas).

**12. 39. 2 Input Terminals and Assignable Sources (Areas)**

	S-VIDEO	VIDEO	Y-PB-PR	COMP1/RGB1	COMP2/RGB2
NTSC(480i)	⊙	⊙	⊙	x	⊙
PAL/SECAM	⊙	⊙	⊙	x	⊙
HDTV(720p)	x	x	⊙	x	⊙
SDTV(480p)	x	x	⊙	x	⊙
HDTV(1080i)	x	x	⊙	x	⊙
PC-98	x	x	x	⊙	⊙
VGA1	x	x	x	⊙	⊙
VGA3	x	x	x	⊙	⊙
MAC13	x	x	x	⊙	⊙
VGA VESA	x	x	x	⊙	⊙
SVGA1	x	x	x	⊙	⊙
SVGA2	x	x	x	⊙	⊙
MAC16	x	x	x	⊙	⊙
XGA1	x	x	x	⊙	⊙
XGA2	x	x	x	⊙	⊙
MAC19	x	x	x	⊙	⊙
MAC21	x	x	x	⊙	⊙
SXGA1	x	x	x	⊙	⊙
SXGA2	x	x	x	⊙	⊙
SXGA3	x	x	x	⊙	⊙
USER1					
USER2					
USER3					
USER4					
USER5					
USER6					
USER7					
USER8					
USER9					
USER10					
AUTO	⊙	⊙	⊙	⊙	⊙

※ User Source specification is only possible in the input terminal used during Source (Area) assignment

## 12.40 Clamp : 'U30' (55H 33H 30H)

Definition : Specifies the clamp function

Command : 'U30' (55H 33H 30H)  
Parameter type : Special parameter (Refer to 7.4.12 Parameter for Clamp.)  
Reply time : 3 seconds  
Restrictions : None except when there is no Source (Area) signal

Operation mode

Standby mode	Power ON mode	Cool-down mode	Emergency mode
x	⊙	x	x

⊙ Communication Examples

◇ When setting the clamp function to "BP"

```
CTLR  '!' '1' SP 'U30' SP '0' CR
DLA    '@' '1' SP '0' CR
```

◇ When requesting the current clamp function setting (if it is set to "ST")

```
CTLR  '?' '1' SP 'U30' CR
DLA    '@' '1' SP '0' SP '1' CR
```

## 12.41 Operation Mode Query : 'Z03' (5AH 30H 33H)

Definition : Requests current operation mode

Command : 'Z03' (5AH 30H 33H)

Parameter type : Special parameter (Refer to 7.4.7 Projector Operation Mode Parameter.)

Reply time : 3 seconds

Restrictions : Query only

Operation mode

Standby mode	Power ON mode	Cool-down mode	Emergency mode
⊙	⊙	⊙	⊙

When the POWER OFF command is received in the Power ON mode, the Projector first enters the Cool-Down mode for about 20 seconds to cool down the lamp, then automatically enters the Standby mode. (For information on each operation mode, refer to 10. Projector Operation Modes.) Since the POWER ON command cannot be accepted in the Cool-Down mode, first query (issue a request for data) the operation mode to confirm that the Projector is in the Standby mode, then transmit the POWER ON command to turn on the Projector again.

⊙ Communication Examples

◇ When requesting the current operation mode (if the Projector is in the standby mode)

CTLR '?' '1' SP 'Z03' CR

DLA '@' '1' SP '0' SP '0000' CR

## 12.42 Source (Area) Query : ' Z 0 5 ' ( 5 A H 3 0 H 3 5 H )

Definition : Asks for the Source (Area) setting actually assigned on the Projector.

Command : ' Z 0 5 ' ( 5 A H 3 0 H 3 5 H )  
 Parameter type : (Refer to 11.1 Projector Sources (Areas) and Source (Area) Numbers.)  
 Reply time : 3 seconds  
 Restrictions : Query only

Operation mode

Standby mode	Power ON mode	Cool-down mode	Emergency mode
×	⊙	×	×

※This command is used to request the current Source (Area) setting actually assigned on the Projector.  
 To obtain the Source (Area) setting status for each input terminal, use the 12.39 Source (Area) Assignment command.

⊙ Communication Example

◇ When requesting the current Source (Area) setting actually assigned on the Projector (if SVGA1 is actually assigned)

```

CTRLR  '?' '1' SP 'Z05' CR
DLA    '@' '1' SP '0' SP '000A' CR
  
```

## 12.43 Shift Up : 'U 3 4' (5 5 H 3 3 H 3 4 H)

Definition : Moves projection lens up (M4000 Series only)

Command : 'U 3 4' (5 5 H 3 3 H 3 4 H)  
 Parameter type : Special parameter (Refer to 7.4.13 Shift Up/Down Parameter)  
 Reply time : 3 seconds  
 Restrictions : No query

Operation mode

Standby mode	Power ON mode	Cool-down mode	Emergency mode
×	◎	×	×

◎ Communication Example

```

CTLR  '!' '1' SP 'U34' SP '1' CR          '!' '1' SP 'U34' SP '0' CR
DLA   '@' '1' SP '0' CR                    '@' '1' SP '0' CR
  
```

※ Be sure to transmit the STOP command after transmitting the START command.

## 12.44 Shift Down : 'U 3 5' (5 5 H 3 3 H 3 5 H)

Definition : Moves projection lens down (M4000 Series only)

Command : 'U 3 5' (5 5 H 3 3 H 3 5 H)  
Parameter type : Special parameter (Refer to 7.4.13 Shift Up/Down Parameter)  
Reply time : 3 seconds  
Restrictions : No query

Operation mode

Standby mode	Power ON mode	Cool-down mode	Emergency mode
x	⊙	x	x

⊙ Communication Example

```
CTLR  '!' '1' SP 'U35' SP '1' CR          '!' '1' SP 'U35' SP '0' CR
DLA    '@' '1' SP '0' CR                    '@' '1' SP '0' CR
```

※ Be sure to transmit the STOP command after transmitting the START command.

## 12.45 Projector Model Query : 'Z 0 A' (5 A H 3 0 H 4 1 H)

Definition : Obtains projector model and software version information.

Command : 'Z 0 A' (5 A H 3 0 H 4 1 H)  
 Parameter type : (\*)  
 Reply time : 3 seconds  
 Restrictions : Query only

Operation mode

Standby mode	Power ON mode	Cool-down mode	Emergency mode
◎	◎	◎	x

\* Model status data format

◇ Requesting current projector model status

'?' '1' SP 'Z 0 A' CR

**Parameter** : None

◎ Tally (response) data format to query

'@' '1' SP Normal Termination Status

SP **Parameter** CR

**Parameter** : 12 byte ASCII characters are used for Model and Software version information.

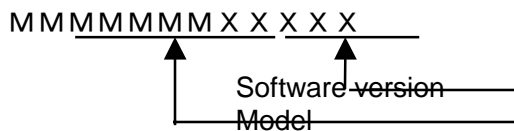

Model	HEX	Definition
'G 1 0 _____'	47H 31H 30H 2DH 2DH 2DH 2DH	G10 Series Projector
'D 0 2 _____'	44H 30H 32H 2DH 2DH 2DH 2DH	G20 Series Projector
'L 0 1 _____'	4CH 30H 31H 2DH 2DH 2DH 2DH	M4000 Series Projector

◎ Communication Example

◇ When the projector is a M4000 series projector with software version 1.4.0

CTLR ' ? ' ' 1 ' SP ' Z0A ' CR  
 DLA '@' ' 1 ' SP ' 0 ' SP ' L01----00140 ' CR

## 12.46 Current Channel Selection : 'U 3 1' (5 5 H 3 3 H 3 1 H)

Definition : Selects and requests current channel information.

Command : 'U 3 1' (5 5 H 3 3 H 3 1 H)  
 Parameter type : (\*)  
 Reply time : 3 seconds  
 Restrictions :

Operation mode

Standby mode	Power ON mode	Cool-down mode	Emergency mode
x	⊙	x	x

\* Channel selection/Current channel request format

◇ When selecting channels

['!'] ['1'] SP ['U 3 1'] SP **Parameter**

CR

**Parameter** : Channel Number

Channel selection. (Refer to 7.4.14 Channel Parameter.)

An error message will be returned if the channel specified is not set.

When the channel is selected, input will switch to the line set to that channel, and after analyzing the signal input from that line, the appropriate source (area) will automatically be selected from the sources registered in that channel.

◇ Requesting current channel selection

['?'] ['1'] SP ['U 3 1'] CR

⊙ Tally (response) data format to query

['@'] ['1'] SP Normal Termination Status

SP **Parameter** CR

**Parameter** : Current channel number

Currently selected channel number. (Refer to 7.4.14 Channel Parameter.)

When the current channel number is 'FF' this means that there is no channel selected.

⊙ Communication Examples

◇ When selecting Channel 1

```
CTLR  '! '1' SP 'U31' SP '01' CR
DLA      '@' '1' SP '0' CR
```

◇ When requesting Current Channel (if Channel 2 has been selected.)

```
CTLR  '?' '1' SP 'U31' CR
DLA      '@' '1' SP '0' SP '02' CR
```

## 12.47 Channel Setting : 'U 3 2' (5 5 H 3 3 H 3 2 H)

Definition : Sets and requests channel data.

Command : 'U 3 2' (5 5 H 3 3 H 3 2 H)  
 Parameter type : (\*)  
 Reply time : 3 seconds  
 Restrictions :

Operation mode

Standby mode	Power ON mode	Cool-down mode	Emergency mode
◎	◎	◎	×

\* Format for setting and requesting channel data

◇ When setting channel data

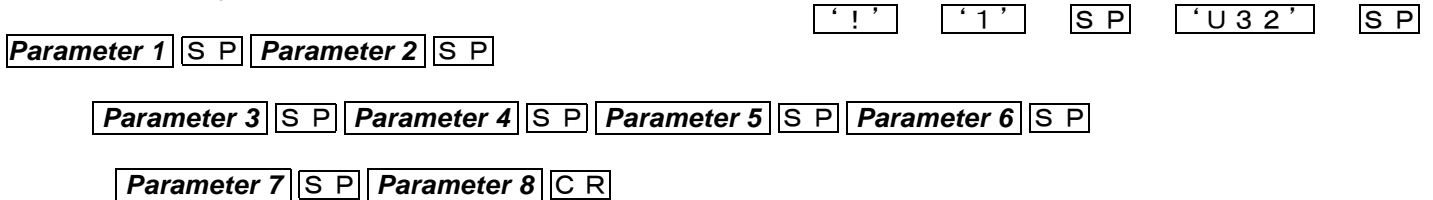

**Parameter 1** : Channel number  
 Channel number being set. (Refer to 7.4.14 Channel Parameter.)

**Parameter 2** : Input terminal information  
 Information about the input terminal that inputs the source (area).  
 (Refer to 7.4.6 Input Select Parameter)

**Parameter 3 ~ Parameter 7** : Source (area) setting  
 Parameter 3 – Parameter 7 specify the source that will be registered to the channel.  
 Bit assignment of "1" means registered, and "0" means not registered.

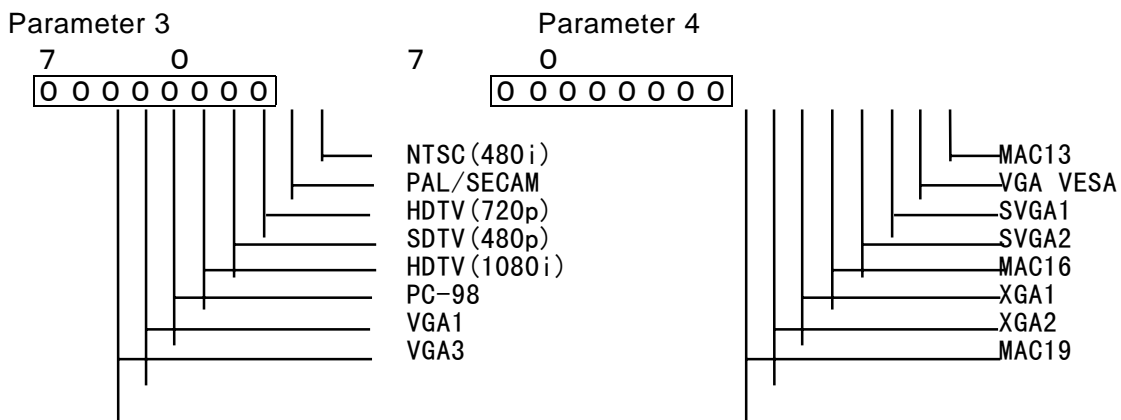

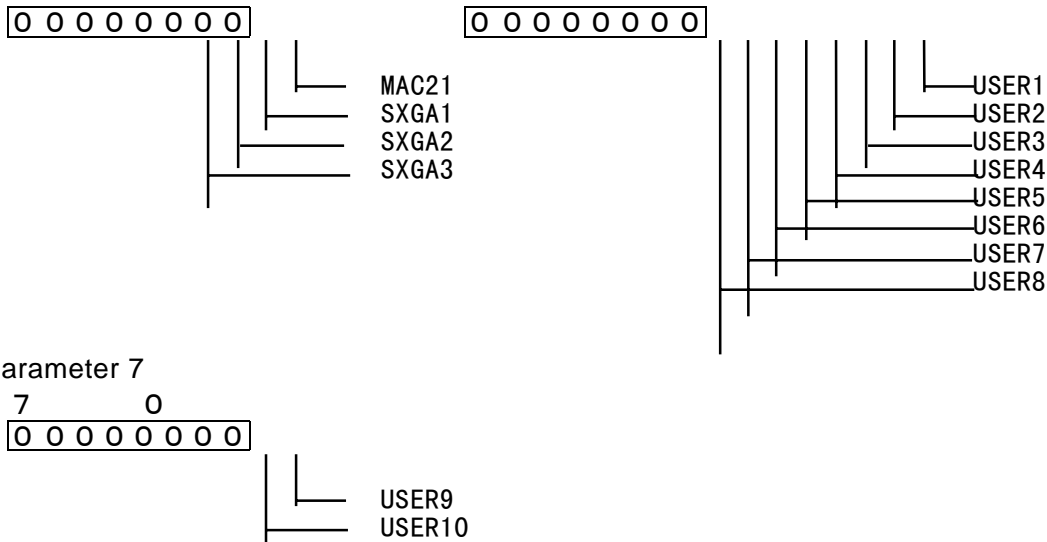

**Parameter 8** : Switcher number

Number for switcher's input select. (Refer to 7.4.15 Switcher Number Parameter.)

When a command is received from the switcher, the channel with a registered switcher number matching the command parameter will be automatically selected.

◇ When requesting current channel data

'?' '1' SP 'U 3 2' SP Parameter

CR

**Parameter** : Channel number

Indicates current channel number. (Refer to 7.4.14 Channel Parameter.)

◎ Tally (response) data format to query

'@' '1' SP Normal Termination Status SP **Parameter 1** SP **Parameter 2** SP  
**Parameter 3** SP **Parameter 4** SP **Parameter 5** SP **Parameter 6** SP  
**Parameter 7** SP **Parameter 8** CR

**Parameter 1** : Channel number

Channel number setting. (Refer to 7.4.14 Channel Parameter.)

**Parameter 2** : Input Terminal Information

Information about the input terminal that inputs the source (area) information.  
 (Refer to 7.4.6 Input Select Parameter)

**If Parameter 2 is " F F " this means that the specified channel is not set.**

**Parameter 3 ~ Parameter 7** : Source (area) setting

Parameter 3 – Parameter 7 indicate the source that has been registered in the channel.  
 Bit assignment "1" means registered, and "0" means not registered.

**Parameter 8** : Switcher Number

Number for switcher's input selection. (Refer to 7.4.15 Switcher Number Parameter.)

© Communication Examples

- ◇ When setting Channel 1 data (if input terminal is COMP2/RGB2; registered sources are VGA3, XGA1, SXGA3 and User1; and there is no corresponding switcher.)

```
CTLR  '!' '1' SP 'U32' SP '01' SP '04' SP '80' SP '20' SP '08' SP '01'  
      SP '00' SP '00' CR  
DLA   '@' '1' SP '0' CR
```

- ◇ When requesting Channel 2 data (if input terminal is COMP1/RGB1; registered sources are XGA1, SXGA3 and User9; and switcher 2 has been set.)

```
CTLR  '?' '1' SP 'U32' SP '02' CR  
DLA   '@' '1' SP '0' SP '02' SP '03' SP '00'  
      SP '20' SP '08' SP '00' SP '01' SP '02' CR
```

## 12.48 User Source Query : 'U 3 3' (5 5 H 3 3 H 3 3 H)

Definition : Obtains registered user source information.

Command : 'U 3 3' (5 5 H 3 H 3 3 H)  
 Parameter type : (\*)  
 Reply time : 3 seconds  
 Restrictions : Query only

Operation mode

Standby mode	Power ON mode	Cool-down mode	Emergency mode
◎	◎	◎	×

\* User Source Query Format

'?' '1' SP 'U 3 3' SP Parameter

CR

**Parameter** : User Source

Indicates the user source number being requested.

Parameter	HEX	Definition
'1 8'	31H 38H	U S E R 1
'1 9'	31H 39H	U S E R 2
'1 A'	31H 41H	U S E R 3
'1 B'	31H 42H	U S E R 4
'1 C'	31H 43H	U S E R 5
'1 D'	31H 44H	U S E R 6
'1 E'	31H 45H	U S E R 7
'1 F'	31H 46H	U S E R 8
'2 0'	32H 30H	U S E R 9
'2 1'	32H 31H	U S E R 1 0

◎ Tally (response) data format to query

'@' '1' SP Normal Termination Status SP **Parameter 1** SP **Parameter 2** SP

**Parameter 3** SP **Parameter 4** SP **Parameter 5** SP **Parameter 6** CR

**Parameter 1** : User Source

Indicates the registered 9 character (spaces may be included) User Source name. When all 9 characters are spaces, this means that the user source is not registered.

**Parameter 2** : Input Terminal

Indicates User Source (Area) information for the input terminal. (Refer to 7.4.6 Input Select Parameter.) The input terminal number selected at the time of user source registration is set.

**Parameter 3** : Basic Source (Area)

The Source (Area) that was specified or set in "AUTO" during User Source (Area) registration is set as the Basic Source (Area).

**Parameter 4** : User Source Horizontal Frequency

Indicates a value that is equivalent to 100 times the horizontal frequency (kHz) converted to a 4-byte

hexidecimal ASCII value.

Example: When horizontal frequency is 33.75kHz, this parameter is '0D2F' (3375)

**Parameter 5** : User Source Vertical Frequency

Indicates a value that is equivalent to 100 times the vertical frequency (Hz) converted to a 4-byte hexidecimal ASCII value.

Example: When vertical frequency is 60Hz, this parameter is '1770' (6000)

**Parameter 6** : Number of Horizontal Pulses in 2V Period

Indicates the count of horizontal pulses during 2V period.

### © Communication Examples

- ◇ When requesting User Source 2 registration (if the selected terminal is COMP2/RGB2; the basic source number is 4 (HDTV(1080i)) at the time of User Source registration; Source Name is 'HD1035I\_R'; Horizontal Frequency is 33.75kHz; Vertical Frequency is 60.00Hz; and 2V Period Pulse Count is 1125)

```
CTLR  '?' '1' SP 'U33' SP '02' CR
DLA   '@' '1' SP '0' SP 'HD1035I_R' SP '04'
      SP '04' SP '0D2F' SP '1770' SP '0465' CR
```

- ◇ When requesting User Source 3 registration (if nothing is registered)

```
CTLR  '?' '1' SP 'U33' SP '03' CR
DLA   '@' '1' SP '0' SP ' ' SP '00'
      SP 'FF' SP '0000' SP '0000' SP '0000' CR
```

## 12.49 Switcher Selection : 'W00' (57H 30H 30H)

Definition : Changes channels according to commands from the Switcher. The Projector searches for the Channel setting in Switcher Input Selection that is sent from the Switcher to the Projector, and switches to that Channel if channel setting exists.

Command : 'W00' (57H 30H 30H)  
 Parameter type : The Switcher's input switching number. (Refer to 7.4.15 Switcher Number Parameter.)  
 Reply time : 3 seconds  
 Restrictions : No Query

### Operation mode

Standby mode	Power ON mode	Cool-down mode	Emergency mode
×	⊙	×	×

### ⊙ Communication Examples

◇ When specifying Switcher 2 (if a channel specifying input switcher 2 exists.)

```

CTLR  '! '1' SP 'W00' SP '0002' CR
DLA   '@' '1' SP '0' CR
  
```

◇ When specifying a Switcher Number (if a channel specifying Switcher 3 does not exist.)

```

CTLR  '! '1' SP 'W00' SP '0003' CR
DLA   '@' '1' SP 'A09' CR
  
```

# 13. APPENDIX

## 13.1 External Control Command List

Command	Character	HEX
Hide	'U00'	55H 30H 30H
Back Color	'U01'	55H 30H 31H
Horizontal Position	'U02'	55H 30H 32H
Vertical Position	'U03'	55H 30H 33H
Phase	'U04'	55H 30H 34H
Tracking	'U05'	55H 30H 35H
Contrast	'U06'	55H 30H 36H
Brightness	'U07'	55H 30H 37H
Sharpness	'U08'	55H 30H 38H
Color	'U09'	55H 30H 39H
Tint	'U0A'	55H 30H 41H
Color Temperature	'U0B'	55H 30H 42H
R-Gain	'U0C'	55H 30H 43H
G-Gain	'U0D'	55H 30H 44H
B-Gain	'U0E'	55H 30H 45H
Power	'U0F'	55H 30H 46H
Menu Auto Off	'U10'	55H 31H 30H
Line Display	'U11'	55H 31H 31H
Sleep Time	'U12'	55H 31H 32H
Zoom W	'U13'	55H 31H 33H
Zoom T	'U14'	55H 31H 34H
Focus +	'U15'	55H 31H 35H
Focus -	'U16'	55H 31H 36H
Right/Left Reverse	'U17'	55H 31H 37H
Top/Bottom Invert	'U18'	55H 31H 38H

Decoder	'U19'	55H 31H 39H
Input Select	'U1A'	55H 31H 41H
Transfer Rate	'U1B'	55H 31H 42H
Lamp Time	'U1C'	55H 31H 43H
ID	'U1D'	55H 31H 44H
Bass	'U1E'	55H 31H 45H
Treble	'U1F'	55H 31H 46H
Volume	'U20'	55H 32H 30H
Audio Muting	'U21'	55H 32H 31H
Quick Alignment	'U2A'	55H 32H 41H
Text Mode	'U2C'	55H 32H 43H
Resize	'U2D'	55H 32H 44H
Aspect Change	'U2E'	55H 32H 45H
Source (Area) Assignment	'U2F'	55H 32H 46H
Clamp	'U30'	55H 33H 30H
Operation Mode Query	'Z03'	5AH 30H 33H
Source (Area) Query	'Z05'	5AH 30H 35H
Shift Up	'U34'	55H 33H 34H
Shift Down	'U35'	55H 33H 35H
Model Status	'Z0A'	5AH 30H 41H
Current Channel Selection	'U31'	55H 33H 31H
Channel Setting	'U32'	55H 33H 32H
User Source	'U33'	55H 33H 33H
Switcher Selection	'W00'	57H 30H 30H

### 13.2 RS-232C Port Pin Configuration

RS-232C Control Port			
D-SUB 9-pin (Male)	Pin No.	Signal	Definition
	1	N/A	Not used
	2	R x D (RD)	Receive data
	3	T x D (SD)	Transmit data
	4	N/A	Not used
	5	GND	GND
	6	N/A	Not used
	7	N/A	Not used
	8	N/A	Not used
	9	N/A	Not used