

# D-ILA™ Projector Technology: The Path to High Resolution Projection Displays

W. P. Bleha  
Vice President, JVC Digital Image Technology Center

## Introduction

JVC is leading the way to the next generation of high-resolution large screen projection displays with the continuing development of the D-ILA™ (Direct Drive Image Light Amplifier) technology. The D-ILA technology builds on the high luminance, high resolution ILA™ Super Projectors that established new standards of projector excellence over 7 years ago.

D-ILA is JVC's proprietary reflective-mode active matrix liquid crystal display commonly referred to as LCOS (liquid crystal on single crystal silicon) in the industry. LCOS displays promise to revolutionize the high-resolution projection display market both in virtual personal displays and in personal and group projection displays.

## D-ILA Image Modulator Technology

JVC has developed a technology that combines the high performance of the Hughes-JVC ILA® technology and the lightweight features of the TFT-LCD. Figure 1 shows a photograph of the D-ILA display modulator, which has a display aperture of only 0.9 inches. This technology is a reflective liquid-crystal design where electronic signals are directly addressed to the device.<sup>1,2</sup> The light valves use active matrix addressing of the liquid crystal to achieve the spatial modulation. The active matrix consists of an array of electrical switches, (MOS transistors) and addressing electronics. The sources and drains of the transistors are connected to the columns and pixel electrodes. The gates are connected to the row electrode. The electrical image signal is sampled successively into a sample-and-hold circuit (S/H) in the columns. Eight contiguous columns are sampled by 1 S/H register. When a full line of data has been sampled, a row electrode is enabled, opening the channels of all the transistors on this selected row. The charges on the S/Hs are transferred to the capacitance of the

corresponding pixel. The gate pulse is then removed, isolating the charge. The process is repeated for successive rows. The image information is updated at the vertical refresh rate. This is shown schematically in Figure 2. Since the nematic liquid crystal responds to voltage level directly, the gray scale is determined by the value of voltage set on each pixel. This reduces the data rates required to address the multi-gray levels sequentially as in the case of bi-stable devices such as the DMD, and thus reduces the required driver complexity for the D-ILA.

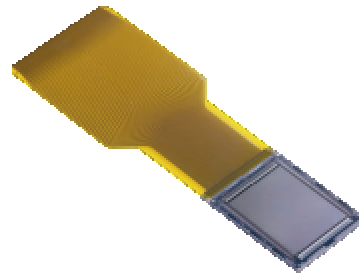

Fig. 1. D-ILA device. The image diagonal is 0.9 inches, 4:3, (1365 x 1024 pixels)

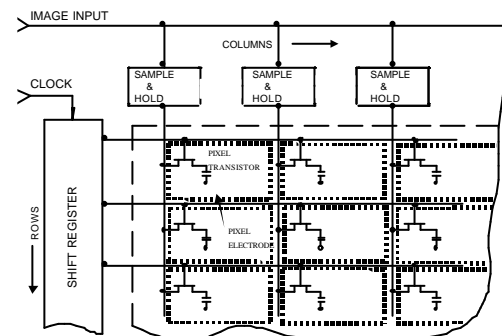

Fig. 2. Schematic of image information flow in the D-ILA device

The D-ILA X-Y matrix of pixels is configured on a C-MOS substrate using the

planar process standard in IC technology. The 0.5 micron CMOS technology used is well developed and this results in high yields. Each pixel is covered, except for a small border, with an aluminum reflective pixel electrode. The driving transistor is connected to this reflective pixel electrode. The homeotropic (vertically aligned) liquid crystal is sandwiched between the reflective pixel electrode and continuous transparent ITO electrode. The thickness of the liquid crystal layer is ~ 3 micrometers. The liquid crystal material has a negative dielectric constant necessary for homeotropic alignment, and also low viscosity for video-rate response. The voltage applied to the selected pixel of the matrix makes the liquid crystal above the pixel change birefringence (move to the "on-state" in Figure 4) and thus modify the polarization state of the projection light in the D-ILA. See the discussion in the section on D-ILA projector technology.

#### Device structure

Figure 3 shows a cross sectional image of the D-ILA device. The display area of the D-ILA device is 0.907" diagonal with a 1365 (H) x 1024 (V) pixel array. The D-ILA device can reproduce true SXGA images on a large screen with high brightness, high contrast and fast response time. A lightly doped drain structure is used in each pixel MOS transistor to improve the break down voltage. In operation the voltage applied to the liquid crystal at maximum transmission is 3.6V.

Three metal layers are formed on the silicon chip: the first metal layer for the driving circuit, the second for the light blocking layer, and the third for reflective pixel electrode. The array of 1365 x 1024 pixel electrodes, with a size of 13.0 x 13.0 micrometers each, are separated by 0.5 micrometers. The D-ILA device can be driven with high speed image signals resulting from the high carrier mobility of the crystalline silicon.

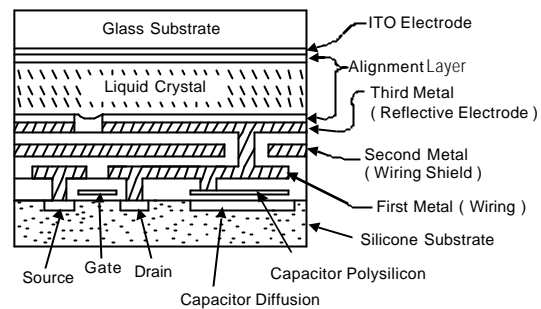

Fig. 3. Cross-section of D-ILA device

The reflectivity and light blocking structure of the silicon chip substrate are important factors in achieving a projected image of up to 4000 lumens. The pixel electrodes of the D-ILA device have a 93% aperture ratio, and have high intrinsic reflectivity. The insulating layers formed between each metal layer are made flat and smooth by chemo-mechanical polishing techniques. The final aluminum pixel mirror approaches a reflectivity of 91%.

The light blocking layer is formed under the mirror electrode in order to prevent light leakage to the transistor located on the first metal layer in the silicon chip. Light leakage would activate the transistor. Each metal layer also has anti-reflective layers on both sides. A light-induced voltage drop in the pixel electrode could cause decreased projection light output due to decreasing liquid crystal modulation. With anti-reflection layers, no voltage drop was observed with over 4000 lumens light output in the projection system. It will be possible to produce projection systems with greater than 10,000 lumens using D-ILA image modulators.

#### Liquid Crystal Alignment

Homeotropic alignment of the liquid crystal allows a high device contrast ratio in the visible light spectrum range since, in a tunable birefringence mode,<sup>3</sup> the birefringence of the liquid crystal is near zero at the threshold off-state voltage. This allows the theoretically highest contrast ratio for any liquid crystal or micro-mechanical device. The liquid crystal molecules are aligned almost perpendicular to the surface

with a small pre-tilt angle at off state (black). A low pre-tilt angle is the most important factor in achieving high contrast ratios and good quality in the projected image. Figure 4 shows a schematic of the homeotropic liquid crystal alignment. There is a range of pre-tilt angles in the black off-state best suited for producing a high contrast ratio and a good uniform image without disclination. This is about a 1° pre-tilt. With this pre-tilt the intrinsic theoretical device contrast ratio for an  $f/4.8$  optical system is greater than 2000:1

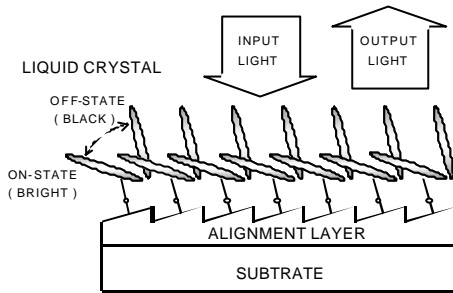

Fig. 4. Homeotropic LC alignment used in the D-ILA device

This high D-ILA image modulator contrast ratio is ultimately limited by the optical system of the projector, in particular, the polarizing beam splitters. In order to achieve a much higher contrast ratio, the use of a quarter wave plate “super contrast mode”<sup>4</sup> is used to eliminate a geometric cause of contrast ratio degradation in the polarizing beam splitters. This is discussed in the D-ILA projector technology section. D-ILA image modulators have achieved greater than 1000:1 sequential contrast ratio in an optimized optical system using the super contrast mode.

#### Temporal response time

The D-ILA device has a true video-rate response time: the rise time plus fall time equals less than 16 milliseconds. The temporal response curve is shown in Figure 5. In general, the response time of liquid crystal layers is strongly related to the layer thickness. Reflective mode permits a thinner liquid crystal cell gap compared to transmissive mode LCDs because in this mode the light passes through the liquid crystal twice - effectively doubling the modulation. In addition the pre-tilt angle of liquid crystal is a determining factor for

response time. The pre-tilt angle is set at a high enough value to avoid potential liquid crystal artifacts that can occur at very low tilt

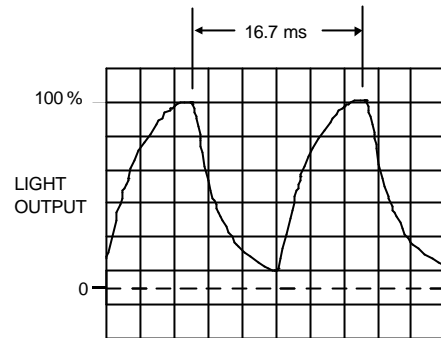

angles while maintaining video-rate response.

Fig. 5. Time response of D-ILA. The rise and decay times total < 16 msec

#### Thermal stability

Figure 6 shows the voltage versus transmission curve changes with various temperatures of T curve at a wide range of temperatures. This is a measure of how the light transmitted by the liquid crystal varies as a function of voltage driving each pixel. There is almost no change in the front slope of the V-T curves with temperature. This thermal stability of the device is required in high brightness projection systems so that ambient temperature variations do not change the image characteristics.

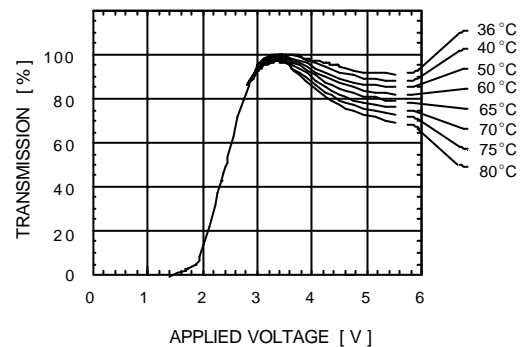

Fig. 6. D-ILA Liquid Crystal Transfer Characteristic as a function of temperature

#### D-ILA Specifications

The main specifications of the D-ILA image modulator are shown in Table 1. The D-ILA image modulator has achieved true SXGA resolution, high brightness projection capability of 4000 lumens, a video-rate response time and has the capability of a high >1000:1 projector sequential contrast ratio.

### D-ILA Projector Technology

As previously discussed in the D-ILA device section, the driving IC controls the voltage across the liquid crystal layer between reflective pixel electrode and transparent electrode based on image signal level. This signal level determines the intermediate levels, or gray scale, of the image. Polarized light from the light source (Xenon lamp) passes through the activated liquid crystal and is reflected by reflective pixel electrode for each selected pixel. The liquid crystal molecules change birefringence according to the signal voltage by tilting as shown in Figure 4, thus changing the polarization direction of the illumination light.

A schematic of the optical system for a single D-ILA device is shown in Figure 7. The individual operation for the RGB D-ILAs is the same. The light from the arc lamp is separated into two linear polarization states before it reaches the D-ILA. One state is reflected in the PBS and reaches the D-ILA device. In the G15 and M4000L Models, a polarization combiner is used before the PBS to partially convert the second state into the first and increase the efficiency of the illumination by ~50%. Then the polarized light is reflected by pixel electrode and modulated by the liquid crystal again.

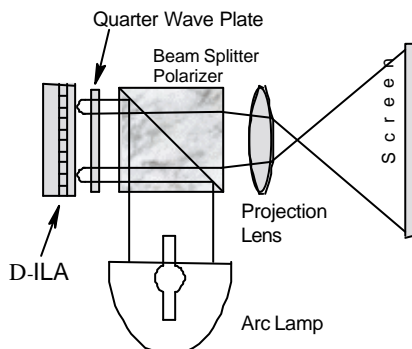
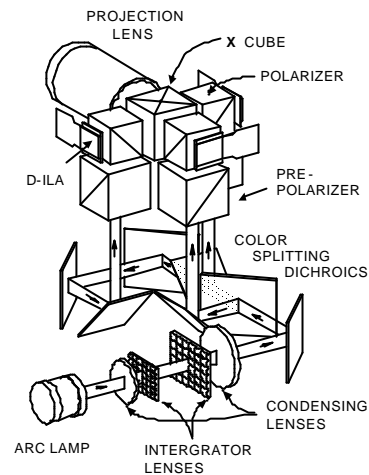

Fig 7. Basic optical schematic of D-ILA

projector

For pixels that have image information (highlight and gray level), the polarized light is rotated through 90 degrees for highlight and partially rotated for gray level. The rotated light is transmitted through the PBS to the projection lens to be finally imaged on the projection screen. For the pixels that have no image information (black), the polarized light remains unchanged after



leaving the D-ILA and then reflected back to the lamp by the PBS.

Fig. 9. G Series optical system

The G Series D-ILA projectors have 3 D-ILA devices for R, G, and B channels. Each device has its own PBS. The modulated output projection light from the 3 D-ILAs is combined by a crossed dichroic prism, which transmits the full color image to the projection lens for imaging on the projection screen.<sup>5</sup> Figure 8 shows the optical schematic of the G Series projectors, including the input xenon arc lamp, optical integrator, and dichroic splitter that sends the RGB light components to the respective D-ILAs. The optical system used in the DLA M4000L is shown in Figure 9. This system has been redesigned for higher luminance output using a 1.6 kW xenon lamp. Both systems use the 0.9 inch 1365x1024 pixel D-ILA image modulator.

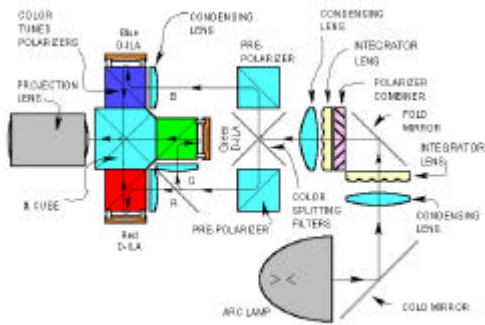

Fig. 9. DLA M4000L optical system

### D-ILA Projector Features

#### Adaptive Digital Pixel Conversion Technology

JVC's innovative Adaptive Digital Pixel Conversion (DPC) technology optimizes picture quality no matter what the input signal resolution to assure smooth, clear images without the annoying jagged edges. The DPC scales the image information to the native resolution of 1365 x 1024 pixels with a minimum of interpolation error. Variable scanning frequency with horizontal scanning frequencies ranging from 15kHz to 82kHz assures compatibility with a wide range of source signals. Vertical scan frequencies of 50 to 78 Hz are accommodated. The D-ILA is addressed at double the vertical frequency of the input signal. However the liquid crystal responds at the rate shown in Figure 5.

#### Digital Gamma Correction

The 10-bit digital gamma correction circuitry provides accurate gray scale and color reproduction. The projectors use the same gamma value (2.2) for both the computer and video inputs.

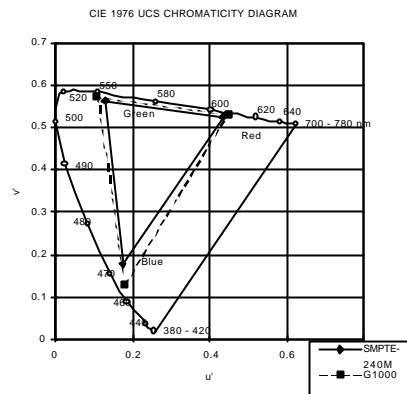

Fig. 10. Color Gamut of G Series D-ILA projector

The color gamut is shown in Fig. 10. The color is reproduced at 8 bits per color. (16.8 million colors). The color reproduction corresponds closely to SMPTE 240M. The color uniformity between 2 G Series projectors is  $\Delta U V < .05$ .

### Future development

Multi-mega pixel modulators are possible with D-ILA technology. Thus it will be possible in the future to reach projection display resolutions, while maintaining highest picture quality, equivalent to 70mm film. These remarkable developments will bring electronic projection technology into many new areas of image display. And by using the latest developments of IC and LC technology, D-ILA systems will be produced with the highest performance and yields and the lowest cost/pixel of any technology.

Table 1. D-ILA image modulator specifications

Effective Display area	18.468mm(H), 13.878mm(V)
Resolution	1365(H) x 1024(V)
Pixel pitch	13.5 micrometer x 13.5 micrometer
Sequential Contrast Ratio	>1000:1
Aperture Ratio	93%
Response time	Rise plus fall <16msec

References:

1. Atsushi Nakano, Akira Honma, Shintaro Nakagaki and Keiichiro Doi, "Reflective active matrix LCD: D-ILA." SPIE Proceedings 1998, Vol 3296, p. 100.
2. H. Kurogane, K. Doi, T. Nishihata, A. Honma, M. Furuya, S. Nakagaki, I. Takanashi, "Reflective AMLCD for Projection Displays: D-ILA™, Society for Information Display International Symposium Digest of Technical Papers, Vol. XXIX, 1998, p. 33.
3. A.M. Lackner, J.D. Margerum, L.J. Miller, "Photostable Tilted-Perpendicular Alignment of Liquid Crystals for Light Valves," Society for Information Display International Symposium Digest of Technical Papers, Vol. XXI, 1990, p. 98.
4. R.D. Sterling, W.P. Bleha, "ILA Projectors for Advanced Applications," Proceedings of the International Display Workshops, 1997, p. 809.
5. F. Tatsumi, S. Moriya, Y. Ishizaka, "Optical System Using 3 Pieces of D-ILA Panel Module," Proceedings of the International Display Workshops 1998, p. 753.